

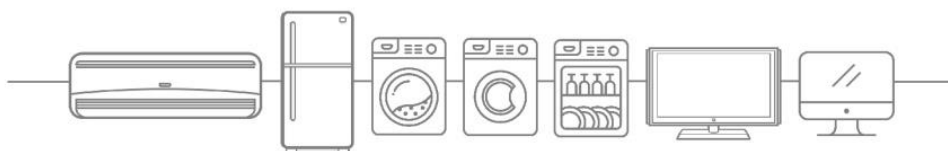

Australian Government

New Zealand Government

Consultation Regulation Impact Statement Three Phase Cage Induction Motors



The Energy Efficiency and Conservation Authority (EECA) on behalf of the Equipment Energy Efficiency (E3) Program.

Creative Commons Licence



Consultation Regulation Impact Statement Three Phase Cage Induction Motors is licensed under a [Creative Commons Attribution 4.0 New Zealand licence](https://creativecommons.org/licenses/by/4.0/). Inquiries about the licence and any use of this document should be emailed to star@eeca.govt.nz.

Disclaimer

EECA has exercised due care and skill in preparing and compiling the information and data in this publication. While reasonable efforts have been made to ensure that the contents of this publication are factually correct, EECA does not accept responsibility for the accuracy or completeness of its contents. This publication is intended to provide reference material for general information purposes only. It does not constitute legal or other professional advice. EECA disclaims liability, to the extent permitted by law, for any liabilities, losses, damages and costs arising from any reliance on the information contained in this publication. You should seek legal or other professional advice in relation to your specific circumstances.

This document is available at: [Regulatory requirements under review | EECA](#)

Contents

Figures.....	4
Tables.....	4
Executive Summary.....	6
1. Background.....	9
Electric motors and their uses in society.....	9
Three phase electric motors market.....	11
Local regulations.....	11
International regulations.....	14
2. Problem.....	16
Low uptake of energy efficient products, despite their availability.....	16
Alignment with international regulations.....	18
Compliance remains a challenge for both the governments and industry.....	19
Global commitments and targets to be met.....	21
3. Options and projected costs, benefits and impacts.....	22
Scope and MEPS.....	22
Registration.....	27
Family of models.....	27
Nameplate.....	27
Labelling.....	27
Minor technical changes.....	28
Analysis of secondary options.....	29
4. Preferred policy option.....	30
5. Conclusion.....	30
6. Implementation and timing.....	31
7. Questions for stakeholders.....	32
Appendix 1: Cost benefit approach and parameters.....	35
Parameters and assumptions.....	35
Calculation of sales and stock.....	37
Stock and energy modelling approach.....	39
Other factors related to stock modelling.....	41
Calculation of energy consumption.....	43

Average efficiency increase due to policy options	45
Average motor cost increase due to policy options	45
Government and industry costs.....	46
Timeframe and discount rates	47
Electricity prices	48
Greenhouse gas emission factors	48
Value of greenhouse gas emissions avoided	48
Peak demand reduction.....	48
Appendix 2: Sensitivity analysis	49
Appendix 3: Motor energy use by sector and end use	53
Appendix 4: Glossary	56
Appendix 5: References	57
Appendix 6: Electricity emissions factors	59

Figures

Figure 1: Motor types (scope of CRIS in grey).....	9
Figure 2: Three phase electric motor example	10
Figure 3: Pump with a three phase electric motor	10
Figure 4: Annual E3 (Australia and New Zealand) three phase electric motor registrations by efficiency class.....	17
Figure 5: Annual three phase electric motors sold in New Zealand by efficiency class	18
Figure 6: Annual net imports from Australian trade data by size category	38
Figure 7: Example of historical and forecast sales of category (2: 0.73-<4kW).....	39
Figure 8: Annual net sales by size category New Zealand	39
Figure 9: Example - graphic representation of stock model.....	40
Figure 10: Examples of survival functions 20-year half life	40
Figure 11: Examples of survival functions 12-year half life	41
Figure 12: Estimated stock by size category by year (historical to 2019, forecast post 2020): Australia ..	42
Figure 13: Estimated stock by size category by year (historical to 2020, forecast post 2020): New Zealand	43
Figure 14: Three phase electric motor imports, Australia by application	54

Tables

Table 1: Estimated sales of three phase electric motors for 2024	11
Table 2: IEC Efficiency Classes.....	13
Table 3: Energy efficiency requirements by country	14

Table 4: Output power regulated by country	15
Table 5: Duty types covered country	15
Table 6: Observed marking from compliance activity (n=62).....	20
Table 7: MEPS options	23
Table 8: MEPS options cost benefit Australia - Level 1.....	24
Table 9: MEPS options cost benefit Australia - Level 2.....	24
Table 10: MEPS options cost benefit New Zealand - Level 1	24
Table 11: MEPS options cost benefit New Zealand - Level 2	25
Table 12: Embedded three phase electric motor sensitivity analysis – Level 1	26
Table 13: Embedded three phase electric motor sensitivity analysis – Level 2	26
Table 14: Non-compliance three phase electric motor sensitivity analysis – Level 1	26
Table 15: Non-compliance three phase electric motor sensitivity analysis – Level 2	26
Table 16: Current and proposed Family of Models Definition	27
Table 17: Results of Secondary Analysis Registration Changes	29
Table 18: Results of Secondary Analysis Labelling Changes	30
Table 19: Primary modelling assumptions and parameters	35
Table 20: Assumptions used in analysis of secondary options.....	37
Table 21: Primary modelling assumptions and parameters continued.....	37
Table 22: Expected half-life for motors by size category.....	41
Table 23: Share of sales attributed to industrial sector (Australia and New Zealand)	41
Table 24: Average output power by size category and poles (kW)	43
Table 25: Average hours of operation by size category and sector (annual hours)	44
Table 26: Average efficiency by size category and poles (75% load).....	45
Table 27: Average purchaser price by size category and poles (AUD)	46
Table 28: Government and industry costs (AUD\$)	47
Table 29: Discount rate sensitivity analysis – Australia Discount rate (real) – Level 1.....	49
Table 30: Discount rate sensitivity analysis – Australia Discount rate (real) – Level 2.....	49
Table 31: Discount rate sensitivity analysis – New Zealand Discount rate (real) – Level 1	49
Table 32: Discount rate sensitivity analysis – New Zealand Discount rate (real) – Level 2	49
Table 33: Carbon price sensitivity analysis – Australia (Discount rate 7% real) – Level 1	50
Table 34: Carbon price sensitivity analysis – Australia (Discount rate 7% real) – Level 2	50
Table 35: Carbon price sensitivity analysis – New Zealand (Discount rate 5% real) – Level 1	50
Table 36: Carbon price sensitivity analysis – New Zealand (Discount rate 5% real) – Level 2	50
Table 37: Embedded motors sensitivity analysis – Australia and New Zealand – Level 1.....	51
Table 38: Embedded motors sensitivity analysis – Australia and New Zealand – Level 2.....	51
Table 39: Non-compliant motors sensitivity analysis - Australia and New Zealand – Level 1.....	52
Table 40: Non-compliant motors sensitivity analysis - Australia and New Zealand – Level 2.....	52
Table 41: Product’s share of motors’ electricity consumption.....	53
Table 42: Electricity consumed by all motors in New Zealand: 2022	55
Table 43: GHG emission factors for electricity (kg CO ₂ -e/kWh) for Australia and New Zealand	59

Executive Summary

This Consultation Regulation Impact Statement (CRIS) has been prepared to consider policy options to improve the energy efficiency of three phase cage induction motors supplied in Australia and New Zealand. Three phase electric motors are used in commercial and industrial applications with common examples being pumps, compressors, and conveyor belts. Three phase electric motors and the systems they drive are estimated to account for 38% and 34% of electricity use in Australia and New Zealand respectively. Given the large amount of energy use, small efficiency gains can have a large impact.

Bare three phase electric motors and motors embedded in or packaged with machines are regulated in Australia and New Zealand and have been since 2001 and 2002 respectively.

A range of policy options is considered including increasing the scope of products regulated, and increasing the Minimum Energy Performance Standards (MEPS). Less significant changes considered include registration changes, and new labelling requirements where the registration number must be displayed, or information must be disclosed on technical datasheets etc. In addition to this are more technical changes proposed to align with the European Union eco-design requirements and to improve international alignment.

The New Zealand Energy Efficiency and Conservation Authority (EECA) has prepared this CRIS on behalf of the Equipment Energy Efficiency (E3) programme. The purpose of this document is to explain the barriers to the uptake of more efficient three phase electric motors, potential regulatory options to address them, and the benefits and costs of each option. Following feedback from stakeholders a Decision Regulation Impact Statement (DRIS) will be prepared for consideration by the Energy and Climate Change Ministerial Council (ECMC) in Australia, and the New Zealand Government.

Some of the barriers preventing the uptake of more efficient three phase electric motors are information asymmetry, and split incentives. A large number of three phase electric motors are embedded in or packaged with machines, meaning the purchaser does not have the information available on the efficiency of the three phase electric motor. In some cases, the operating costs and capital costs of the business are managed by different departments meaning, while a more efficient three phase electric motor may have a lower lifetime cost, they may not be purchased as they have a higher upfront capital cost.

The policy options for scope and MEPS are presented below. There are three options considered:

- Option 0: BAU - no changes to the current regulation in Australia and New Zealand: MEPS remain at IE2 level for three phase electric motors between 0.73kW (inclusive) to less than 185kW.
- Option 1 (referred to as Level 1 in this CRIS), where the scope of the regulations is increased from 0.73kW to 185kW to 0.12kW to 375kW. Efficiency levels for small three phase electric motors would be set at IE2, and for medium motors and large motors it would be IE3. Level 1 would be introduced in 2027.
- Option 2 (referred to as Level 2 in this CRIS) builds on Level 1 introduced in 2027, and for a set range (75kW (inclusive) to 200kW (inclusive), 2, 4 and 6 poles) the MEPS requirements would be increased to IE4 from 2029.

The benefits of these options are presented below. The cost benefit analysis only includes bare three phase electric motors owing to the large number of applications where machines with three phase electric motors (embedded in or packaged with) are used, and the limited data on those applications. As 65% of three phase electric motors are estimated to be packaged with or embedded within machines, a sensitivity analysis has also been included to model this. This results in conservative benefit estimates, which are likely to be much larger.

Level 1: Australia

	Small 0.12kW (inclusive) to less than 0.75kW	Medium 0.75kW (inclusive) to less than 185kW	Large 185kW (inclusive) to less than 375kW	Total
Total Benefits (NPV, \$M) AUD	\$30	\$174	\$40	\$243
Total Costs (NPV, \$M) AUD	\$8	\$36	\$8	\$52
Net Benefits (NPV, \$M) AUD	\$22	\$138	\$31	\$192
Benefit Cost Ratio	3.8	4.9	4.8	4.7
Emissions reduction (cumulative kt CO ₂ -e)	48	278	64	390
Cumulative Energy Savings (GWh)	488	2,876	705	4,069

7 % discount rate, cumulative savings to 2060, installed stock to 2050

Level 2: Australia

Total Benefits (NPV, \$M) AUD	\$333
Total Costs (NPV, \$M) AUD	\$106
Net Benefits (NPV, \$M) AUD	\$227
Benefit Cost Ratio	3.1
Emissions reduction (cumulative kt CO ₂ -e)	529
Cumulative Energy Savings (GWh)	5,720

7 % discount rate, cumulative savings to 2060, installed stock to 2050

Level 1: New Zealand

	Small 0.12kW (inclusive) to less than 0.75kW	Medium 0.75kW (inclusive) to less than 185kW	Large 185kW (inclusive) to less than 375kW	Total
Total Benefits (NPV, \$M) NZD	\$8	\$20	\$4	\$32
Total Costs (NPV, \$M) NZD	\$2	\$3	\$1	\$6
Net Benefits (NPV, \$M) NZD	\$6	\$17	\$3	\$26
Benefit Cost Ratio	4.5	6.2	5.0	5.5
Emissions reduction (cumulative kt CO ₂ -e)	8	19	3	30
Cumulative Energy Savings (GWh)	152	371	63	587

5 % discount rate, cumulative savings to 2060, installed stock to 2050

Level 2: New Zealand

Total Benefits (NPV, \$M) NZD	\$37
Total Costs (NPV, \$M) NZD	\$8
Net Benefits (NPV, \$M) NZD	\$29
Benefit Cost Ratio (BCR)	4.8
Emissions reduction (cumulative kt CO ₂ -e)	34
Cumulative Energy Savings (GWh)	679

5 % discount rate, cumulative savings to 2060, installed stock to 2050

The results show that there is significant benefit in increasing the scope and MEPS requirements of three phase electric motors in Australia and New Zealand (with the conservative approach). The sensitivity analysis completed for three phase electric motors within machines (embedded in or packaged with) results in a 25% decrease in the BCR for Australia and 55% for New Zealand. This shows that it is cost effective to regulate three phase electric motors within machines (embedded in or packaged with), including in the conservative case where they are assumed to have three time the compliance cost, and receive no benefit.

1. Background

Electric motors and their uses in society

There are many different types of electric motors. They work by converting electrical energy into mechanical energy to create rotational motion. Electric motors are used extensively throughout Australia and New Zealand in many sectors including residential, commercial, and industrial applications. Some examples in the residential space are extractor fans used in kitchens and bathrooms, and motors that drive whiteware appliances. Examples in commercial and industrial settings are workshop machinery, pumps for irrigation, compressors, and manufacturing plants.

Globally, electric motors and electric motor systems¹ account for over 40% of electricity consumption². In Australia and New Zealand, electric motors account for 47% and 43% of total electricity demand. It is estimated that around 80% of this electricity consumption by motors is from three phase motors³, with the remaining 20% consumed by smaller, but more numerous, single-phase motors in both markets. Three phase electric motors and systems are estimated to account for 38% and 34% of electricity use in Australia and New Zealand respectively.

Three phase cage induction motors, referred to as three phase electric motors in this document, are a subset of electric motors, and are the most widely used type of electric motors in commercial and industrial applications. Pumps, compressors, fans and conveyers found in workshop and manufacturing machinery are common examples of where this type of electric motor can be found.

Given the wide range of applications and the significant electricity consumption, proposals to improve the energy efficiency of three phase electric motors is the focus of this Consultation Regulation Impact Statement (CRIS).

Figure 1 below shows the types of electric motors and the scope of this consultation.

Figure 1: Motor types (scope of CRIS in grey)

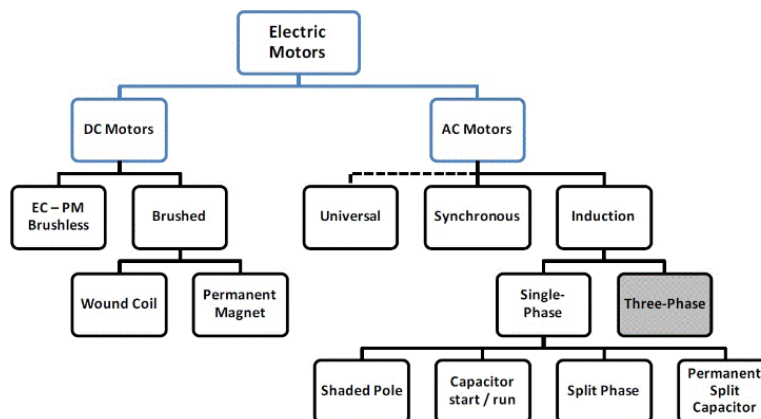

¹ Electric motors in this context include single and three phase electric motors used across industrial, commercial, and residential sectors.

² International Energy Agency (IEA), 2011

³ E3 Product Profile, 2006

The images below in Figure 2 and Figure 3 show examples of three phase electric motors and their application, including three phase electric motors packaged with machines.

Figure 2: Three phase electric motor example

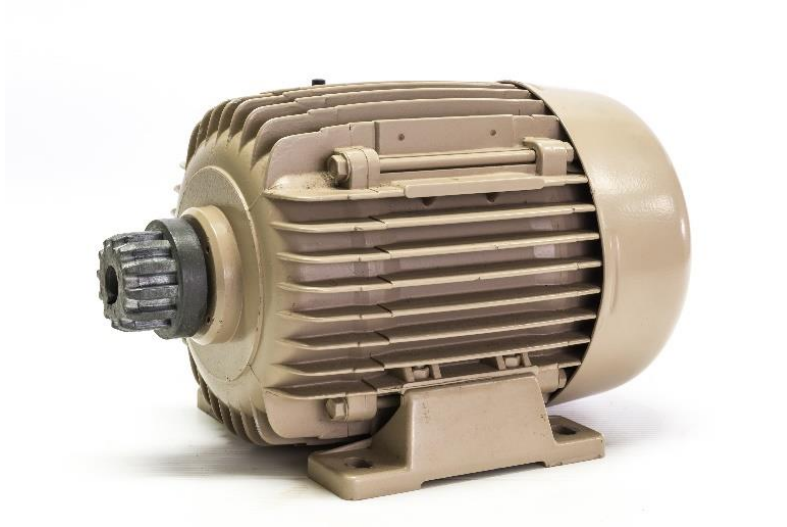

Figure 3: Pump with a three phase electric motor



Three phase electric motors market

Three phase electric motors are a globally traded product. There are no three phase electric motor manufacturing operations in Australia or New Zealand. However, some Australian and New Zealand businesses use parts manufactured elsewhere to assemble motors and motor-gearbox units. The majority of three phase electric motors imported into Australia and New Zealand originate from China, Germany, Italy, Republic of Korea, Brazil, Taiwan, United States of America, Japan, India and France. Major brands include ABB, Baldor, Brook Crompton, CEG, Monarch, Regal Beloit (including Marathon and CMG), Rotek, SEW-Eurodrive, Siemens, Techtop, TECO, Toshiba and WEG.

As stated in the section above, three phase electric motors account for a large amount of electricity consumption, but there are no commercially available sources of detailed (regulated and unregulated) three phase electric motors sales and stock levels for the Australian and New Zealand markets. For regulated three phase electric motors, the New Zealand Regulations require that importers and manufacturers provide annual sales data on each regulated motor. In Australia, the Commonwealth has previously obtained some partial sales information. The Equipment Energy Efficiency (E3) programme⁴ acknowledges that this data has limitations but has used it alongside import-export data to undertake the analysis for this CRIS. E3 welcomes any further data that may be available from industry as part of the consultation process to improve the analysis.

Table 1 below show the estimated annual sales of bare three phase electric motors in scope of the current Australian/New Zealand regulations, and the expanded scope considered in the CRIS.

Table 1: Estimated sales of three phase electric motors for 2024

Country	Current scope 0.73kW (inclusive) to 185kW)	Larger motors 185kW (inclusive) to 375kW	Smaller motors 0.12kW (inclusive) to 0.73kW	Total
New Zealand	19,270	100	18,021	37,391
Australia	116,396	1,072	63,109	180,577

Adding to the complexity, motors can be supplied into the market as individual motors (known as bare motors) or integrated into other equipment (packaged with or embedded within). The challenges associated with embedded motors and compliance are described in the Problem section.

Appendix 3: Motor energy use by sector and end use contains a list of industries that use three phase electric motors

Local regulations

Australia and New Zealand regulate three phase electric motors for energy efficiency and have done so since 2001 and 2002 respectively. These requirements were revised for Australia only in 2006 and again in 2019.

⁴ The Equipment Energy Efficiency (E3) programme is an initiative of the Australian Government, states and territories and the New Zealand Government to improve the energy efficiency of appliances and equipment.

Both countries have legislation that sets out the requirements for regulated parties and requirements the products must meet before supply⁵. These include Minimum Energy Performance Standards (MEPS), labelling requirements, and testing requirements. Regulated parties are required to register their products and ensure they meet any MEPS and labelling requirements.

The requirements for Australia are described in the [Greenhouse and Minimum Energy Standards \(GEMS\) Act 2012](#) and [Greenhouse and Energy Minimum Standards \(Three Phase Cage Induction Motors\) Determination 2019](#), while New Zealand uses the [Energy Efficiency and Conservation \(EEC\) Act 2000](#), and [Energy Efficiency \(Energy Using Products\) Regulations 2002](#).

New Zealand and Australia have different testing, MEPS, and labelling requirements for three phase electric motors, with New Zealand lagging behind Australia and having lower MEPS and older test standards. In 2019 [The New Zealand Government proposed updating the requirements](#) to harmonise with the Australian Determination, and this CRIS is written assuming these requirements are in place in New Zealand.

The regulations cover three phase electric motors in 2, 4, 6 or 8-pole configurations with a rated output power between 0.73 kW (inclusive) to less than 185 kW, and with a rated voltage up to 1100 V AC. Both bare three phase electric motors and three phase electric motors packaged with or embedded in other equipment are covered by the regulations.

There are a number of three phase electric motors which are not covered by the regulations and they include⁶:

- submersible (sealed) motors specifically designed to operate wholly immersed in a liquid,
- motors that are integral to, and not separable from, a driven unit,
- multi-speed motors,
- motors to be used only for short-time duty cycle applications⁷, which have a duty type rating of S2,
- rewind motors (unless it claims to meet IE2, IE3, or IE4 efficiency levels),
- motors that are supplied exclusively to third parties who will incorporate the motors into equipment that will be exported to another country, and
- high slip motors (torque motors).

Currently the MEPS (GEMS level requirement in the Determination) are set at IE2, using the IEC Efficiency Classes presented in Table 2. Motors that meet IE3 can be marked as “high efficiency” under the Australian legislation, which is referred to as “Premium efficiency” under IEC.

⁵ The meaning of supply differs between Australia and New Zealand. In New Zealand the regulations cover sale, lease, hire, and hire-purchase. In Australia the GEMS Act covers offer to supply which includes make available, expose, display, or advertise the product for supply. It also includes commercial use.

⁶ See Section 12 of the Department of Climate Change, Energy, the Environment and Water (DCCEEW), 2019 and Energy Efficiency and Conservation Authority, 2024 for full details concerning all exclusions

⁷ Refer to Electrical Engineering Portal, 2022 for further information on duty types.

Table 2: IEC Efficiency Classes⁸

Class Number	Class Type
IE1	Standard efficiency
IE2	High efficiency
IE3	Premium efficiency
IE4	Super premium efficiency
IE5	Ultra premium efficiency

Three phase electric motors are required to have specific information on their nameplate as per clause 10 of IEC 60034-1 Ed 13 2017. The information they need to be marked with includes maker's name or mark, serial number or identification mark, output, voltage, efficiency class (e.g. IE2 or IE3) and the rated efficiency. Typically, about 15 fields are required to be marked on the rating plate(s).

In 2019 Australia referenced (in the Determination) international test standards (IEC and IEEE) which can be used to show compliance with the regulation requirements. The acceptable test standards are IEC 60034-2-1 Ed 2.0 (2014) (Method 2-1-1B), IEEE 112:2004 and IEEE 112:2017 and cover the major test standards used in both the European Union (EU) and United States (US).

To supply three phase electric motors in Australia or New Zealand, suppliers must register their products online in the E3 registration system. Registrations need to be accompanied by a test report to one of the three approved test standards that demonstrates that products meet the MEPS.

New Zealand Regulations state that three phase electric motors registered in Australia⁹ do not need to be registered in New Zealand but must meet New Zealand MEPS and labelling requirements.

The [Greenhouse and Energy Minimum Standards \(Three Phase Cage Induction Motors\) Determination 2019](#) introduced an ability to group multiple three phase electric motor models on a single registration, known as a family of models. A family of models is intended to reduce testing and registration costs¹⁰, provided the models in the family meet specific requirements, namely:

- be of the same brand, and
- have the same frame size, and
- have the same characteristics for each of the following:
 - number of poles,
 - the duty type, as specified in clause 4 of IEC 60034-1, assigned in accordance with clause 5 of IEC 60034-1,
 - rated output power (in kilowatts), and

⁸ From IEC 60034-30-1 Rotating electrical machines - Part 30-1: Efficiency classes of line operated AC motors (IE code)

⁹ On the E3 registration system

¹⁰ Registration costs include the application fee in Australia (no application fee in New Zealand) and a person's time to complete the application form.

- rely on a single test report that was prepared prior to the application for registration for the model being made under section 41 of the Act, and
- the rated voltage and the rated current must be the same, and
- not contain more than 10 models.

International regulations

A number of countries have energy efficiency (MEPS) requirements for three phase electric motors (Table 3 below), 10 of the 12 (83%) have higher energy efficiency requirements than New Zealand and Australia.

Table 3: Energy efficiency requirements by country¹¹

Country or Region	Energy Efficiency requirement (MEPS)
EU/Switzerland/Turkey/UK/Israel/Ukraine	IE3/IE4 ¹²
USA, Canada, Mexico	~IE3 ¹³
South Korea	IE3
Japan	IE3
China	IE3
Singapore	IE3
Brazil	IE3
Saudi Arabia	IE3
Taiwan	IE3
Australia and New Zealand	IE2
Colombia	IE3
Chile, Ecuador	IE2
India	IE2

In addition to the higher MEPS requirements, major economies ([US](#) and [EU](#)) also have a wider scope. For example, the EU regulates smaller three phase electric motors down to 0.12kW (inclusive) instead of 0.73kW (inclusive), and larger motors up to 1000kW (inclusive), while the US regulates up to 559kW (750hp)¹⁴. Table 4 below shows the size range of regulated motors by country.

¹¹ International Energy Agency (IEA), 2024

¹² 0.12 kW ≤ x < 0.75 kW IE2; IE4 75 kW ≤ x ≤ 200 kW (2, 4, and 6 pole). IE3 for 0.75 kW ≤ x < 75 kW and 200 kW < x ≤ 1000 kW

¹³ The USA will adopt IE3/IE4 equivalent to the EU in 2027: Department of Energy (DoE), 2023

¹⁴ This is based on the regulation to apply from 2027: Department of Energy (DoE), 2023

Table 4: Output power regulated by country¹⁵

	Rated Output (kW)	Rated Output (kW)	Rated Output (kW)
Country	2 & 4 Pole	6 Pole	8 Pole
Australia and New Zealand (current scope)	0.73 - <185	0.73 - <185	0.73 - <185
EU/Switzerland/Turkey ¹⁶	0.12 - 1000	0.12 - 1000	0.12 - 1000
Singapore	0.75 - 375	0.75 - 375	n.a.
Japan	0.75 - 375	0.75 - 375	n.a.
China	0.75 - 375	0.75 - 375	n.a.
USA	0.75 - 559	0.75 - 261	0.75 - 186
Canada	0.75 - 559	0.75 - 260	0.75 - 185
Mexico	0.746 - 373	0.746 - 261	0.746 - 186
South Korea	0.75 - 375	0.75 - 200	0.75 - 200
Brazil	0.75 - 370	0.75 - 370	0.75 - 370
Taiwan	0.75 - 200	0.75 - 200	0.75 - 200

There are also other differences including the duty class of motor regulated (Table 5 below):

Table 5: Duty types covered country

Country	Duty Types Covered
Australia and New Zealand	All but S2
US, Canada, Mexico, South Korea, Brazil	S1
Japan, China	S1, S3 [$\geq 80\%$]
EU/Switzerland/Turkey	S1, S3 [$\geq 80\%$] or [S6 $\geq 80\%$] and others ¹⁷
Singapore	S1, S3 [$\geq 80\%$], S6, S9

In addition to the specific types of three phase electric motors excluded in the regulations, the following types of three phase electric motors are excluded by international regulations:

- a) Motors with integral Variable Speed Drive (VSD) whose performance cannot be measured independently of the drive,
- b) Integral brake motors, and
- c) Motors designed specifically for the traction of electric vehicles.

¹⁵ International Energy Agency (IEA), 2022

¹⁶ EU countries have amended their Ecodesign requirements to extend the scope of their motors regulation to include motors rated at 0.12 kW to less than 0.75 kW at the IE2 level, include 8-pole motors; and extend their upper scope to 1,000 kW. Changes commenced on 1 July 2021.

¹⁷ European Commission, 2019 deems motors capable of *continuous operation* in scope. The tabulated classes are sufficient but not necessary to fall into this category. Continuous operating is also taken to mean *capable of continuous operation at rated power with a temperature rise within the specified insulation temperature class*.

2. Problem

There is a combination of regulatory and market failures in the energy efficiency of three phase electric motors that are contributing to unnecessary electricity use in Australia and New Zealand. These failures are described in the sections below.

The operation of inefficient electrical appliances and equipment increases electricity demand above what it otherwise would be. This increased demand requires increased investment in electricity generation, transmission and distribution, which increases the cost of electricity supplied to all households and businesses. Increased electricity use also contributes to increased greenhouse gas (GHG) emissions, which contributes to climate change. At a consumer level, increased electricity use increases utility bills. Reductions in electricity consumption can lower GHG emissions and help to meet government GHG emission commitments. Reduced electricity use can also reduce stress on electricity grids and reduce the risk of load shedding and blackouts. Energy efficiency can help reduce the need to add expensive new power generation or transmission capacity and reduce pressure on energy resources.

Energy efficient appliances use less electricity to achieve the same level of performance as similar models with the same size or capacity. The more energy efficient a model, the less energy it will use and the less it will cost consumers to run. While in Australia the emissions intensity of electricity has been steadily decreasing with the gradual decarbonisation of the electricity grid, significant emissions reductions can still be made from energy efficiency improvements, particularly where regulatory and market failures exist.

In Australia, the GEMS Act¹⁸ objectives include promoting the development and adoption of products that use less energy or produce less greenhouse gases. In New Zealand, the purpose of the Energy Efficiency and Conservation (EEC) Act¹⁹ 2000 includes the promotion of energy efficiency and energy conservation.

Low uptake of energy efficient products, despite their availability

Energy efficient three phase electric motors are available in the market but are not widely used in Australia and New Zealand. Using registration information from the current regulated scope (0.73kW (inclusive) to 185kW) Figure 4 shows that, from 2020 to 2023, 60% of three phase electric motor registrations are IE3, and 12% are IE4. Figure 5 shows 62% of sales are IE3, with very little IE4 sales (1.7%), leaving 36% of energy inefficient motors in the market.

This is more of an issue for three phase electric motors, as this equipment uses a lot of electricity (34% and 38% in New Zealand and Australia respectively)²⁰ and more than they should, due to the operation of inefficient three phase electric motors. This leads to higher electricity costs for society.

There are several factors that could be contributing to the low uptake of energy efficient three phase electric motors. These factors include availability, suitability, cost, information asymmetry, and split

¹⁸ Department of Climate Change, Energy, the Environment and Water (DCCEEW), 2012

¹⁹ Energy Efficiency and Conservation Authority (EECA), 2000

²⁰ Calculations by authors based on E3 Product Profile, 2006 and International Energy Agency (IEA), 2011

incentives. Particularly, when a three phase electric motor is supplied packaged with or embedded in a machine. In such cases:

- The purchaser of the machine does not necessarily have information on the efficiency of the machine, let alone the efficiency of the three phase electric motor(s) within the machine. This means that the energy efficiency or the ongoing running costs and lifetime costs of the three phase electric motors may not be considered as part of the purchase decision. Depending on the use of the machine the upfront purchase cost can be a small part of the lifetime cost of ownership.
- The purchaser of the machine may not be the end user of the machine e.g. for tender contracts, which may mean that the running costs and lifetime cost of the machine (and three phase electric motor) are not considered.
- The three phase electric motor(s) is only one component of the machine and it may not be possible to get the same machine with more efficient three phase electric motor(s).
- The capital expenditure may be managed in a different part of the business to the ongoing running cost (e.g. electricity cost), and so three phase electric motors with lower capital cost (but higher running and lifetime costs) may not be preferred.

Figure 4: Annual E3 (Australia and New Zealand) three phase electric motor registrations by efficiency class

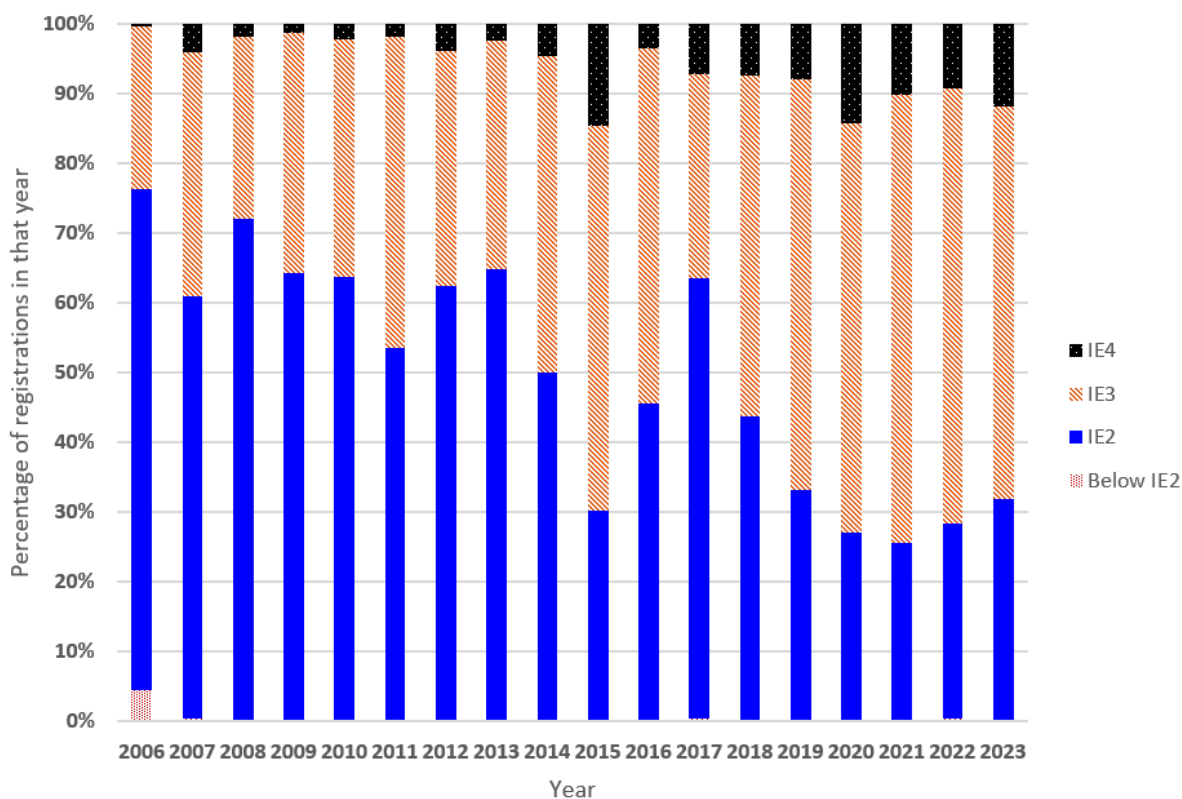
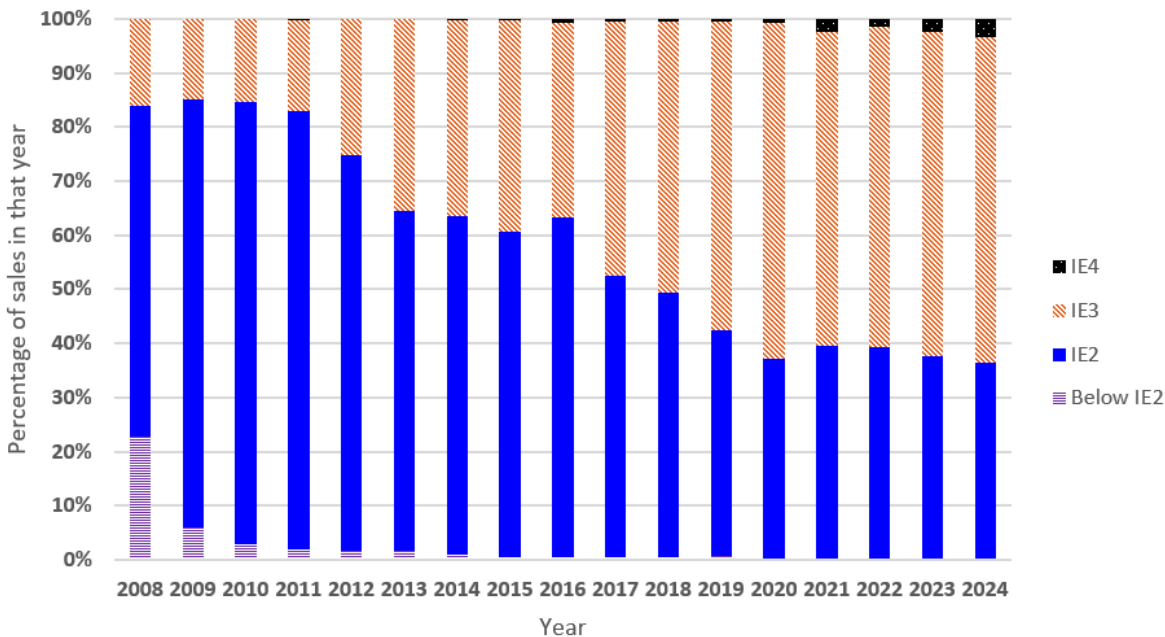

Figure 5: Annual three phase electric motors sold in New Zealand by efficiency class



The introduction of three phase electric motors MEPS in Australia and New Zealand has compelled market participants to supply three phase electric motors with improved energy efficiency (because it is a breach of the regulations to supply three phase electric motors with an efficiency below IE2 level). However, without regulatory intervention IE2 motors will continue to be available and supplied in Australia and New Zealand in significant quantities as shown in Figure 4 and Figure 5. For three phase electric motors outside of the current scope their efficiency may be lower than the MEPS requirement.

Alignment with international regulations

Australia and New Zealand three phase electric motor requirements are currently misaligned with international regulations. In most developed countries (as shown in the International regulations section), MEPS for three phase electric motors are set at IE3 levels or above in most cases. From July 2023, the EU mandated IE4 levels for three phase electric motors from 75 kW to 200 kW (2, 4, and 6 pole) which means New Zealand and Australia are now lagging further behind other countries in terms of performance standards for these products. Failure to increase efficiency levels risks Australia and New Zealand becoming a market for dumping low efficiency three phase electric motors that have long lifetimes and cannot be sold into many other countries; locking in efficiency losses for many years and putting unnecessary load on the electricity system.

Australia and New Zealand have a long-standing policy of harmonising with international energy efficiency standards, wherever it is possible and reasonable to do so. This reduces trade barriers as well as costs to industry and consumers.

There are a number of benefits when Australia and New Zealand align with international markets on energy efficiency, such as reduced compliance cost for industry:

- Compliance with international efficiency requirements would mean easier compliance with New Zealand and Australian requirements.
- Use of international test methods can reduce testing cost and complexity and remove barriers to trade.
- It also supports free trade agreements.
- If the scope of products covered by international requirements are the same as Australian and New Zealand requirements. It simplifies compliance for local and international suppliers.

The requirements introduced in Australia in the 2019 Determination focused on international alignment, which included using the IEC Efficiency Classes to set MEPS, and the use of IEC and IEEE test Standards to show compliance. There are further international alignments that could be introduced such as:

- Increasing the scope of three phase electric motors regulated from the narrow range of 0.73kW (inclusive) to 185kW, to the wider range of three phase electric motors covered by both the EU eco-design requirements²¹ and US DoE requirements²².
- The duty type of motors regulated in Australia and New Zealand is significantly wider than international regulation.

Compliance remains a challenge for both the governments and industry

Embedded three phase electric motors

Three phase electric motors that are supplied as a component of a larger piece of equipment are within the scope of Australia's and New Zealand's regulations. However, the identification of the type of motors packed with or embedded in complex machines remains a challenge for both the governments and industry. It should be noted that the challenges below for three phase electric motors are not limited to Australia and New Zealand, but this consultation enables feedback to be gathered on possible solutions that could address the issue. These challenges include:

- In some cases it is a complex task identifying if a three phase electric motor in a machine is covered by the scope of the Australian and New Zealand regulations, because three phase electric motors can be installed behind covers or in locations or orientations whereby it is impossible to either access or read motor rating plates, unless the equipment is disassembled.
- The same machine may contain a different three phase electric motor depending on when it was manufactured, which results in additional administration for equipment suppliers.
- Three phase electric motors are also often inadequately marked (on the product, and in an advertisement), which makes identifying a model and matching it to a possible registration difficult.

Australian equipment suppliers have stated they are generally unable to obtain from their suppliers the specifications or test reports for motors that are incorporated into many types of equipment. This includes whether the motors are in scope of Australia's regulations and whether the motors meet MEPS requirements. A particular machine could carry a different model of motor with each batch imported (depending on motor supply availability), which can result in complicated and onerous administration obligations for equipment suppliers.

²¹ European Commission, 2019

²² Department of Energy (DoE), 2023

In Australia, for the reasons outlined above, GEMS compliance officers find it difficult to determine whether equipment contains in-scope motors, and whether any in-scope motors meet all the requirements. This issue was identified in the review of the GEMS Act²³.

Nameplate information

As described in the Local regulations section, three phase electric motors are required to have specific information on their nameplate as per clause 10 of IEC 60034-1 Ed 13 2017.

Nameplate markings can be used to easily determine three phase electric motor characteristics, which can be useful when looking to replace or change them. They can also be used to assist in compliance with the identification of the three phase electric motor and what performance requirements it meets.

Compliance activities in Australia have revealed that not all three phase electric motors are complying with the nameplate requirements, as shown in Table 6 below:

Table 6: Observed marking from compliance activity (n=62)

Marking	Percentage carrying marking
Phases	100%
Frequency	100%
Output	98%
Voltage	97%
Speed	94%
Manufacturer	89%
Poles ²⁴	37%
Efficiency Class and Rated Efficiency	40%

Other implementation issues

The current Family of Models definition is narrow, meaning that while the legislation says 10 three phase electric motors can be registered under the same family, in practice this does not occur and far fewer models can be grouped together. This increases the burden on suppliers with additional testing and registration required, compared with the previous Australian Determination which allowed a wider range of motors to be covered by a single registration.

As three phase electric motors are sold packaged with or embedded within machines there are some cases where both the three phase electric motor and the machine are regulated for energy efficiency in Australia and New Zealand. This mostly arises for three phase air conditioners and chillers used for heating and cooling large buildings.

The current scope of regulated air conditioners covers products that can run on mains power, use the vapour compression cycle, are used for space conditioning for human comfort, and can be any

²³ Department of the Environment and Energy, 2019

²⁴ Poles can usually be inferred from supply frequency and operating speed.

capacity²⁵. Chillers covered by energy efficiency regulation must have a capacity of 350kW or more, use the vapour compression cycle, and meet specific temperature requirements for inlet and outlet water temperature. There is a [proposal to regulate smaller chillers as small as 100kW](#).

This situation creates potentially unnecessary regulation, which can lead to unintended consequences like unnecessary burden on industry. By regulating the overall product rather than the individual components, energy efficiency can be achieved without restricting designer choice or adding unnecessary burden.

The three phase electric motors regulation scope already excludes three phase electric motors when they are integral to a product, including situations such as where they:

- share common components, apart from connectors such as bolts, with the driven unit, and
- cannot operate as a motor if separated from the driven unit, even if a temporary end shield or a drive end bearing is fitted.

For example: A motor constructed on the same shaft as a compressor for an air-conditioning unit.

E3 would like stakeholders' views on the above issue of regulating three phase electric motors incorporated into other equipment that is also subject to energy efficiency regulation.

Global commitments and targets to be met

Both New Zealand and Australian governments have signed up to the recent COP28 pledge²⁶ to double energy efficiency and triple renewable energy by 2030. Both countries look to reduce greenhouse gas emissions by 2030 (by 43%²⁷ in Australia and 50%²⁸ in New Zealand), and to achieve net zero by 2050. Due to the widespread use of three phase electric motors and the systems they drive and the associated electricity consumption across Australia and New Zealand (38% and 34% respectively) increased three phase electric motor efficiency will contribute to achieving these targets in a cost-effective manner. As the transition to net zero in 2050 will no doubt see a large increase in electricity use, there is a general need to manage this increase in demand to support the transition.

The International Energy Agency (IEA) has highlighted the importance of energy efficiency in supporting the required energy transition, including the role of standards and labelling regulations. The [IEA has called on all member states to ensure that "all industrial motor sales" are best in class by 2035](#).

²⁵ New Zealand currently only regulates air conditioners with a capacity up to 65kW, but has [Cabinet approval to regulate for above 65kW](#).

²⁶ The United Nations Climate Change Conference, 2023

²⁷ Department of Climate Change, Energy, the Environment and Water (DCCEEW), 2023

²⁸ Ministry for the Environment, 2023

3. Options and projected costs, benefits and impacts

Rationale for government action

Government action may be needed when the market fails to provide the most efficient and effective solution to a problem. A range of regulatory and market failures exist for the energy use of three phase electric motors in Australia and New Zealand. These were described in the Problem section.

The MEPS levels of three phase electric motors in Australia and New Zealand are much less stringent than those in major international markets. This will cost the Australian community up to \$50 million in 2050, in additional energy costs and \$7 million in 2050 in New Zealand. Annual electricity consumption in 2050 will be 380 GWh higher in Australia and 41 GWh higher in New Zealand than it otherwise would be.

In Australia, the GEMS Act objectives include promoting the development and adoption of products that use less energy and produce less GHG. In New Zealand, the purpose of the EEC Act 2000 includes the promotion of energy efficiency and energy conservation. Improved energy efficiency reduces energy consumption, energy costs and GHG emissions for consumers and businesses.

Without government action, the regulatory and market failures identified in the Problem section will persist and worsen over time and the objectives of the GEMS and EEC Acts will not be met.

Policy options

The policy options to address these market and regulatory failures are categorised into two levels, primary and secondary. Primary changes include scope and MEPS options, with secondary changes being changes to registration, labelling requirements, and minor technical changes.

A cost benefit analysis has been completed for the proposed scope and MEPS changes, and the registration and labelling options.

The cost benefit analysis only includes bare three phase electric motors owing to the large number of applications where machines with three phase electric motors (embedded in or packaged with) are used, and the limited data on those applications. As 65% of three phase electric motors are estimated to be packaged or embedded within machines²⁹, a sensitivity analysis has also been included to model this. This results in conservative benefit estimates, which are likely to be much larger.

The modelling approach and assumptions are detailed in Appendix 1: Cost benefit approach and parameters.

Scope and MEPS

Internationally and in Australia and New Zealand MEPS are set using the IEC Efficiency Classes (IE1, IE2, IE3, IE4, and IE5), and can be set at different levels for different sizes of three phase electric motors.

²⁹ EnergyConsult, 2023

Three categories have been created for the primary policy options analysis. These categories consider the current scope of the Australian and New Zealand regulations and the broader scope in international regulations such as in the EU.

- Small: 0.12kW (inclusive) to less than 0.75kW
- Medium (current scope): 0.75kW (inclusive) to less than 185kW
- Large: 185kW (inclusive) to less than 375kW

Table 7 below shows the proposed MEPS options for each of the three categories. These have been chosen to align with international markets and to address the market failures and the low uptake of more energy efficient products, despite their availability.

Table 7: MEPS options

Option	Small 0.12kW (inclusive) to less than 0.75kW	Current scope (medium) 0.75kW (inclusive) to less than 185kW	Large 185kW (inclusive) to less than 375kW
Business As Usual (BAU)	No MEPS	IE2	No MEPS
Level 1	IE2	IE3	IE3
Level 2	IE2	IE4 for 2, 4, and 6 pole, 75kW (inclusive) to 185kW, otherwise IE3	IE4 for 2, 4, and 6 pole, 185kW (inclusive) to 200kW (inclusive), otherwise IE3

The BAU option means no changes to the current regulation in Australia and New Zealand: MEPS remain at IE2 level, and only for three phase electric motors 0.75kW (inclusive) to less than 185kW.

The Level 1 option introduces MEPS at IE2 for small three phase electric motors in Australia and New Zealand in line with the [EU eco-design 2019/1781](#) requirements. This option also brings MEPS levels for the current scope (0.75kW inclusive to less than 185kW) and the extended scope covering larger three phase electric motors (185kW inclusive to less than 375kW) to IE3 – one step closer to the EU eco-design requirements (IE4 for 75kW-220kW motors).

The Level 2 option is similar to the Level 1 option, with the addition of a more stringent MEPS level (IE4) for 2, 4, and 6 pole 75kW (inclusive) to 200kW (inclusive) three phase electric motors, to align New Zealand and Australian regulations with the EU eco-design requirements.

While the EU regulates three phase electric motors up to 1000kW, this is not being considered in this consultation document because larger three phase electric motors (above 375kW) have different market dynamics than smaller three phase electric motors. Three phase electric motors at these large sizes have very large energy consumption meaning the running cost and energy efficiency is likely considered as part of the purchasing decision. They also are sold in far smaller volumes due to their cost and limited applications.

Another important factor is laboratory capability to test regulated products. Regulating products that are difficult and expensive to test can have significant unintended market consequences. This can include unintended reduction in market size and competitiveness, and increased non-compliance. Given

these factors, regulating three phase electric motors above 375kW is unlikely to have the energy savings impact to justify a regulatory intervention.

Increasing the scope and MEPS requirements to Level 1 and Level 2 will also address the market failures outlined in the Problem section, because low efficiency three phase electric motors will not be supplied in the Australian and New Zealand markets. It will also help to bring New Zealand and Australia into international alignment and help to support the energy transition.

A cost benefit analysis has been completed to show the impact (benefit, cost, and benefit to cost ratio of each MEPS level), in Table 8, Table 9, Table 10, and Table 11 below. Level 1 is assumed to be introduced in 2027, while Level 2 is assumed to be introduced 2 years later - in 2029. Note that the results for Level 2 include the impacts of Level 1.

Table 8: MEPS options cost benefit Australia - Level 1

	Small 0.12kW (inclusive) to less than 0.75kW	Current scope (medium) 0.75kW (inclusive) to less than 185kW	Large 185kW (inclusive) to less than 375kW	Total
Total Benefits (NPV, \$M) AUD	\$30	\$174	\$40	\$243
Total Costs (NPV, \$M) AUD	\$8	\$36	\$8	\$52
Net Benefits (NPV, \$M) AUD	\$22	\$138	\$31	\$192
Benefit Cost Ratio	3.8	4.9	4.8	4.7
Emissions reduction (cumulative kt CO ₂ -e)	48	278	64	390
Cumulative Energy Savings (GWh)	488	2,876	705	4,069

7 % discount rate, cumulative savings to 2060, installed stock to 2050

Table 9: MEPS options cost benefit Australia - Level 2

Total Benefits (NPV, \$M) AUD	\$333
Total Costs (NPV, \$M) AUD	\$106
Net Benefits (NPV, \$M) AUD	\$227
Benefit Cost Ratio	3.1
Emissions reduction (cumulative kt CO ₂ -e)	526
Cumulative Energy Savings (GWh)	5,720

7 % discount rate, cumulative savings to 2060, installed stock to 2050

Table 10: MEPS options cost benefit New Zealand - Level 1

	Small 0.12kW (inclusive) to less than 0.75kW	Current scope (medium) 0.75kW (inclusive) to less than 185kW	Large 185kW (inclusive) to less than 375kW	Total
Total Benefits (NPV, \$M) NZD	\$8	\$20	\$4	\$32
Total Costs (NPV, \$M) NZD	\$2	\$3	\$1	\$6

	Small 0.12kW (inclusive) to less than 0.75kW	Current scope (medium) 0.75kW (inclusive) to less than 185kW	Large 185kW (inclusive) to less than 375kW	Total
Net Benefits (NPV, \$M) NZD	\$6	\$17	\$3	\$26
Benefit Cost Ratio	4.5	6.2	5.0	5.5
Emissions reduction (cumulative kt CO ₂ -e)	8	19	3	30
Cumulative Energy Savings (GWh)	152	371	63	587

5 % discount rate, cumulative savings to 2060, installed stock to 2050

Table 11: MEPS options cost benefit New Zealand - Level 2

Total Benefits (NPV, \$M) NZD	\$37
Total Costs (NPV, \$M) NZD	\$8
Net Benefits (NPV, \$M) NZD	\$29
Benefit Cost Ratio	4.8
Emissions reduction (cumulative kt CO ₂ -e)	34
Cumulative Energy Savings (GWh)	679

5 % discount rate, cumulative savings to 2060, installed stock to 2050

The results show that there is benefit in increasing the regulated scope and MEPS requirements of three phase electric motors. Level 1 has a total net benefit of AU\$192 million for Australia and NZ\$26 million for New Zealand. Level 2 builds on this and results in a higher net benefit of AUD\$227 million for Australia and NZ\$29 million for New Zealand.

The introduction of MEPS for small three phase electric motors at IE2 levels is cost effective with a Benefit Cost Ratio (BCR) of 3.8 in Australia and 4.5 in New Zealand. For large motors the Level 2 option has a similar BCR to Level 1 for New Zealand (4.8 and 5.0), but for Australia it is less (3.1 and 4.8).

While Level 2 has a lower BCR than for Level 1 (3.1 and 4.7 for Australia, and 4.8 and 5.5 for New Zealand) it provides the highest net benefit AUD\$227 million and NZ\$29 million for Australia and New Zealand respectively. It also provides the greatest international alignment of the policy options examined.

The estimated peak demand reduction from the above options is 48 MW in Australia and 5 MW in New Zealand in 2050. These values are minimal compared to the energy savings and, hence, have not been quantified in the Cost Benefit Analysis (CBA), but are provided here for context.

Appendix 2: Sensitivity analysis for three phase electric motors within machines (embedded or packaged with) results in a 25% decrease in the BCR for Australia and 55% for New Zealand (Table 12 and Table 13). This shows that it is cost effective to regulate for three phase electric motors within machines (embedded or packaged with), with the conservative assumptions of:

- Three phase electric motor sales embedded in or packaged with machines are two times the sales of bare three phase electric motors
- The models that are not currently registered would incur three times the administrative burden of bare three phase electric motor registration (testing, time to complete registration, etc.)
- There are no benefits claimed for these three phase electric motors.

Table 12: Embedded three phase electric motor sensitivity analysis – Level 1

	Australia	Australia	New Zealand	New Zealand
	Embedded Motors Scenario	Base Case	Embedded Motors Scenario	Base Case
Total Benefits (NPV, \$M)	\$243	\$243	\$32	\$32
Total Costs (NPV, \$M)	\$90	\$52	\$15	\$6
Net Benefits (NPV, \$M)	\$154	\$192	\$17	\$26
Benefit Cost Ratio	2.7	4.7	2.1	5.5

Australia discount rate is 7%, New Zealand discount rate is 5%

Table 13: Embedded three phase electric motor sensitivity analysis – Level 2

	Australia	Australia	New Zealand	New Zealand
	Embedded Motors Scenario	Base Case	Embedded Motors Scenario	Base Case
Total Benefits (NPV, \$M)	\$333	\$333	\$37	\$37
Total Costs (NPV, \$M)	\$144	\$106	\$17	\$8
Net Benefits (NPV, \$M)	\$189	\$227	\$20	\$29
Benefit Cost Ratio	2.3	3.1	2.2	4.8

Australia discount rate is 7%, New Zealand discount rate is 5%

It is known that some three phase electric motors are supplied in Australia and New Zealand that do not comply with the current requirements, but the extent cannot be confidently quantified. There is no certainty that 100% compliance with a higher (IE3 or IE4) MEPS could be enforced. To understand the impact of non-compliance an assumed 10% non-compliance is shown below (Table 14 and Table 15). This reduces the costs and benefits by 10%.

Table 14: Non-compliance three phase electric motor sensitivity analysis – Level 1

	Australia	Australia	New Zealand	New Zealand
	10% non-compliance	Base Case	10% non-compliance	Base Case
Total Benefits (NPV, \$M)	\$219	\$243	\$29	\$32
Total Costs (NPV, \$M)	\$47	\$52	\$5	\$6
Net Benefits (NPV, \$M)	\$172	\$192	\$23	\$26
Benefit Cost Ratio	4.7	4.7	5.5	5.5

Australia discount rate is 7%, New Zealand discount rate is 5%

Table 15: Non-compliance three phase electric motor sensitivity analysis – Level 2

	Australia	Australia	New Zealand	New Zealand
	10% non-compliance	Base Case	10% non-compliance	Base Case
Total Benefits (NPV, \$M)	\$299	\$333	\$33	\$37
Total Costs (NPV, \$M)	\$95	\$106	\$7	\$8
Net Benefits (NPV, \$M)	\$204	\$227	\$26	\$29
Benefit Cost Ratio	3.1	3.1	4.8	4.8

Australia discount rate is 7%, New Zealand discount rate is 5%

This shows that there is still significant benefit after accounting for possible non-compliance.

Registration

Family of models

The definition of Family of Models in the current regulation is narrow. Although the current regulation allows registration of up to 10 models in a family, this rarely occurs due to the requirements placed on models to be in a family. Table 16 below shows the current Family of Models definition, and the proposed changes to this definition, including the removal of the requirement of the same brand and frame size, and the addition of models to have the same efficiency level, stator, rotor and winding insulation.

Table 16: Current and proposed Family of Models Definition

Current Family of Models definition	Proposed Family of Models definition
<ul style="list-style-type: none"> • Be the same brand, • Have the same frame size, • Have the same characteristics, <ul style="list-style-type: none"> ○ Number of poles, ○ Duty type, ○ Rated output (in kilowatts), • Rely on single test report, • Not contain more than 10 models, • Have the same rated voltage and rated current. 	<ul style="list-style-type: none"> • Have the same characteristics, <ul style="list-style-type: none"> ○ Number of poles, ○ Same efficiency level, ○ Duty type, ○ Rated output (in kilowatts), ○ Have the same stator, rotor and same winding insulation temperature class ○ Have the same rated voltage and rated current • Rely on a single test report, • Not contain more than 10 models.

Removing brand and frame size would enable more three phase electric motors to be registered under a single family, which would reduce the registration burden on industry. It will also ensure that a family of models does not include three phase electric motors that have different energy performance characteristics.

Nameplate

To improve compliance with the nameplate marking requirements, it is proposed to require a picture of the nameplate to be provided at the point of registration. This would enable assessment of the nameplate to ensure compliance with the legislation, and also provide compliance officers with a point of reference to link three phase electric motors with registrations. This has been implemented for other regulated products, such as external power supplies which have nameplate marking requirements and are required to provide an image of the nameplate at point of registration.

Labelling

Compliance officers often have difficulty linking three phase electric motors with product registrations. This hinders compliance activities to ensure that all three phase electric motors are registered (including three phase electric motors within machines [embedded or packaged with]). To enable clear linking of three phase electric motors to product registrations, it is proposed to introduce a requirement to display

the current registration number of the three phase electric motor when the motor is offered for supply. This requirement would cover in store offers, digital (online) offers, and print-based offers of three phase electric motors. It would also include where a machine that contains regulated three phase electric motors is offered for supply.

In addition, under the [EU eco-design 2019/1781](#) requirements (Annex 1 point 2), certain information about three phase electric motor products is required to be visibly displayed in the following places:

- technical data sheet or user manual supplied with the three phase electric motor, and
- manufacturers, importers, and authorised representative websites, and
- technical data sheet supplied with the product which contains a regulated three phase electric motor.

It is proposed that the above requirements are introduced in Australia and New Zealand to help overcome the market failures of lack of information and awareness for the purchaser of the three phase electric motors. The relevant information to be included would be:

- Rated efficiency at 100%, 75%, and 50% load (at 25 degrees C and 50 Hz),
- efficiency level IE2, IE3, or IE4,
- product's model identifier,
- number of poles of the motor,
- the rated power output (kW),
- the rated input frequency (Hz),
- the rated voltage (V),
- the rated speed (rpm).

While the current New Zealand and Australian legislation has nameplate marking requirements, this alone does not resolve the market failures above. It is only required on the nameplate of the three phase electric motor, which may not be seen until it has been purchased, or may not be seen at all, if the three phase electric motor is embedded within a machine without easy access. Requiring this information upfront will provide the information to the purchaser (of either bare motors or motors embedded or packaged with machines), raising the awareness of its efficiency and enabling purchasers to consider this as part of the purchasing process. Introducing this requirement would also assist compliance officers in identifying motors and linking them to product registrations, as the three phase electric motor information will be readily available.

The above changes to labelling requirements would be in addition to the existing nameplate marking requirements, which would remain.

Minor technical changes

This CRIS proposes several minor regulatory changes that would align New Zealand and Australia with the [EU eco-design 2019/1781](#) requirements. These include:

- Decreasing the input voltage range of motors covered from 1100V to 1000V (there are no registrations with a rated input voltage above 1000V, meaning this change will not impact the market),

- Aligning the duty types regulated from all but S2, to only S1, S3 \geq 80%, and S6 \geq 80% (the majority of the market is S2, S1 and S6, meaning this change will only slightly reduce the scope of products covered). The other duty types are used for less time, meaning their energy savings are minimal. They are also not used in a way that enables them to reach a stable temperature,
- Add the exclusions of:
 - Motors with integral variable speed drive whose performance cannot be measured independently of the drive, or
 - that incorporates integral brakes, or
 - designed specifically for the traction of electric vehicles.

In addition to the above, a new version of the currently cited IEC 60034-2-1³⁰ test standard has been published. A technical comparison of *Method 2-1-1B – Summation of losses, additional load losses according to the method of residual loss* has been completed to compare the version cited in legislation with the latest version. This review concludes that for the purposes of the energy efficiency test they are equivalent, and so it is proposed that the IEC 60034-2-1 (Edition 3):2024 Method 2-1-1B be added as a fourth possible test standard to show compliance.

The EU has chosen to regulate VSDs using IEC 61800-9-2:2017. The CRIS does not propose to regulate VSDs at this time. However, the motor that is supplied with a variable speed drive whose performance can be measured independently of the drive is required to comply, which aligns with the EU eco-design approach.

Analysis of secondary options

A summary of the costs and benefits of the secondary options is shown in Table 17 and Table 18. This covers the proposed registration changes relating to family of models and nameplate, and the labelling changes relating to registration number and technical information. It does not include the minor technical changes proposed to scope e.g. duty or testing (IEC 60034-2-1 Method 2-1-1B) as these are considered to have a small monetary benefit and cost but have the benefit of making steps to achieving international alignment.

Table 17: Results of Secondary Analysis Registration Changes

Registration Changes	Australia (AU\$)	New Zealand (NZ\$)
Industry Benefits	\$2,780,000	\$890,000
Industry Costs	\$490,000	\$150,000
Net Benefit industry	\$2,300,000	\$740,000
Government Benefits	\$150,000	\$50,000
Government Costs	\$0	\$0
Net Benefit government	\$150,000	\$50,000

Australia discount rate is 7%, New Zealand discount rate is 5%

³⁰ IEC 60034-2-1 Ed. 2.0 (Bilingual 2014) *Rotating electrical machines – Part 2-1: Standard methods for determining losses and efficiency from tests (excluding machines for traction vehicles)*.

Table 18: Results of Secondary Analysis Labelling Changes

Labelling Changes	Australia (AU\$)	New Zealand (NZ\$)
Industry Benefits	\$0	\$0
Industry Costs	\$208,000	\$65,000
Net Benefit industry	-\$208,000	-\$65,000
Government Benefits	\$153,000	\$49,000
Government Costs	\$0	\$0
Net Benefit government	\$153,000	\$49,000

Australia discount rate is 7%, New Zealand discount rate is 5%

Registration changes are expected to have benefits to industry (AU\$2.3 million in Australia and NZ\$0.74 million in New Zealand), through the reduction of testing and registration costs. There is expected added cost to include the nameplate image at point of registration. The labelling changes include reduced costs of compliance for government. The increased energy efficiency of three phase electric motors due to labelling has not been quantified and is conservative as there will benefit.

4. Preferred policy option

Two policy options have been presented for MEPS and Scope. While Level 1 has a large net benefit of AU\$192 million in Australia and NZ\$26 million in New Zealand, the Level 2 option delivers a greater net benefit of AU\$227 for Australia and NZ\$29 million in New Zealand. The Level 2 option also achieves greater international alignment, and so is the preferred policy option.

Several secondary policy options have been presented and include changes to registration, introduction of labelling requirements, and other minor technical changes, such as the adoption of new test methods. It is preferred to implement all secondary policy options as some of them help to address the policy problem, help to improve compliance, or they align with regulatory best practice.

The combination of the preferred primary policy option and secondary options form a comprehensive regulatory package to address the policy problem. They would reduce the incidence of inefficient electrical equipment and the level of electricity demand in Australia and New Zealand. High electricity demand requires increased investment in electricity generation, transmission and distribution, which increases the cost of electricity supplied to all households and businesses. Increased electricity use also contributes to increased greenhouse gas (GHG) emissions, which contributes to climate change.

5. Conclusion

Three phase electric motors consume a significant amount of electricity in Australia (38%) and New Zealand (34%), and as a result small improvements in energy efficiency can result in large energy savings. There are a range of regulatory and market failures that are preventing the uptake of more efficient motors, including information asymmetry, and lack of international alignment. These problems can be addressed through regulatory measures.

Increasing the scope of the regulations to cover small (0.12kW (inclusive) to less than 0.75kW) and large (185kW (inclusive) to less than 375kW) three phase electric motors would deliver significant benefits for Australia and New Zealand. While the Level 2 policy option has a lower BCR than Level 1, overall it has the highest net benefit (AU\$227 million in Australia and NZ\$29 million in New Zealand) and proposes MEPS levels in line with larger international markets (EU and US).

The secondary options relating to registration would enable improved compliance with nameplate requirements and reduce compliance costs on industry and government with less testing and registration requirements. The secondary options relating to labelling, including the display of the registration number would assist compliance officers with compliance and improve the enforceability of the regulations. Requiring certain information to be included on a three phase electric motor's data sheet and on the data sheet of any machines containing a three phase electric motor would encourage the use of motors above the MEPS requirements, and help to improve the efficiency of three phase electric motors in Australia and New Zealand. These measures would reduce unnecessary electricity consumption and help meet government objectives in both countries. As a result, the preferred policy option is Level 2 requirements for MEPS and scope and to implement all secondary options on registration, labelling, and minor technical changes.

E3 welcomes stakeholder feedback before any recommendations are put forward to Energy Ministers for their consideration.

6. Implementation and timing

Submissions received on the CRIS will be considered in the development of a Decision Regulation Impact Statement, which will then be considered by the Energy and Climate Change Ministerial Council (ECMC) in Australia and the New Zealand Government. In New Zealand the [Energy Efficiency and Conservation Act 2000](#) and [Energy Efficiency \(Energy Using Products Regulations 2002\)](#) are used to implement MEPS and labelling requirements, while in Australia the [Greenhouse and Energy Minimum Standards Act 2012](#) and Determinations are used.

If ECMC and the New Zealand Government agree to changing the requirements for three phase electric motors, then the decision is expected to be implemented as below.

In Australia:

- Three phase electric motors (included those embedded or packaged with machines) imported or manufactured prior to the law change that don't meet the new requirements may still be supplied until stock is depleted. Their registrations will be grandfathered (status changed to "Superseded" in the registration system). Evidence of date of import or manufacture in Australia or New Zealand may be requested for compliance purposes. New import or manufacture of this equipment from the date of the law change is not permitted unless the equipment meets the specified requirements.
- Registered three phase electric motors (included those included those embedded or packaged with machines) imported or manufactured prior to the law change that already meet the new requirements may continue to be supplied. Their registrations will be re-validated and updated to the new GEMS Determination.

- Suppliers wishing to import or manufacture products that are in scope and do not have an approved registration, will need to complete a registration application, pay the registration fee and lodge the application with the GEMS Regulator.
- Unregistered products that fall within the scope of the Determination in Australia are not permitted to be supplied or used for any commercial purpose at any time.

In New Zealand:

- The regulations the three phase electric motor (included those included those embedded or packaged with machines) must comply with are dependent on the date of importation or manufacture in New Zealand.
- If the three phase electric motor is imported or manufactured in New Zealand before the enforcement date of the amended regulations it must comply with the regulations in force prior to the amendment.
- If the three phase electric motor is imported or manufactured in New Zealand from the enforcement date of the amended regulations it must comply with the amended regulations.
- All currently registered three phase electric motors will be assessed against the new requirements and, if they comply, they will be upgraded to the new regulations. If the three phase electric motor registration does not comply, its status will change to superseded, meaning that existing stock imported or manufactured in New Zealand before the enforcement date can be made for sale, lease, hire, or hire-purchase, but no new stock may be imported or manufactured in New Zealand.
- Three phase electric motors captured by the expanded scope and are imported or manufactured in New Zealand from the enforcement date, will need to comply with the amended requirements.

It should be noted that the Trans-Tasman Mutual Recognition Agreement (TTMRA) applies to products supplied in Australia or New Zealand: [Trans-Tasman Mutual Recognition Agreement and Free Trade Agreements | EECA](#). The TTMRA is a cooperation and trading agreement between Australia and New Zealand, which recognises the relationship of the two countries.

7. Questions for stakeholders

E3 seeks feedback from stakeholders regarding the questions below. **Please ensure that you explain your answer.**

- Summary questions
 1. Do you support the proposal to increase the MEPS and /or expand the scope of MEPS for three phase electric motors and why?
 2. What is your preferred option(s) and why?
- Cost benefit and modelling assumptions
 3. Do you agree with the assumptions and parameters used in the cost benefit modelling (listed in Appendix 1: Cost benefit approach and parameters)? If not, can you please provide information on what you consider the assumptions/parameters should be.
 4. Do you agree with the assumptions on the proportion of motors sold as bare motors compared to those embedded or packaged with machines?

5. What do you think will be the impact on competition in the market and three phase electric motor availability if the proposed new MEPS levels are adopted, namely:
 - IE4 MEPS (75kW \leq x \leq 200kW, poles 2, 4, and 6)
 - IE3 MEPS (0.75kW \leq x \leq 375kW)
 - IE2 MEPS for small three phase electric motors (0.12kW \leq x $<$ 0.75kW)
6. The CBA is based on the supply of bare three phase electric motors. Do you think that the supply of three phase electric motors contained within other equipment, such as pumps, fans and compressors, differ significantly in their size, efficiency and other characteristics from the market for bare motors?
7. Do you have any comments on how the market for IE3 motors is changing, compared with the market for IE2 motors, and what factors are driving this change?
8. Figure 12 shows in Australia the overall stock of three phase motors is increasing until 2012 and then declining until 2030 with a slight increase over the next decade. This is largely due to the rapid increase in the period 2000 to 2012 of motors under 4kW. Do you have any insight into why this is the case?
- Minor technical changes
 9. Do you support lowering the voltage threshold to 1,000 V?
 10. Are you supportive of adopting EU duty cycles under regulation?
 11. What are your opinions on regulating the following types of motors: motors with integral variable speed drive; motors incorporating integral brakes; and motors specifically designed for the traction of electric vehicles?
 12. Do you support allowing IEC 60034-2-1 (Edition 3):2024 (Method 2-1-1B) as a test Standard for compliance purposes? This is in addition to IEC 60034-2-1 Ed 2.0 (2014) (Method 2-1-1B), IEEE 112:2004 and IEEE 112:2017 which are allowed in the current GEMS determination.
 13. Should three phase electric motors designed to be used with VSDs be regulated separately to non-VFD motors, and what should MEPS level be (IE2, IE3, etc.)?
- Minimum Energy Performance Standards and scope
 14. Do you support regulating small three phase electric motors (0.12kW \leq x $<$ 0.75kW) at IE2 levels?
 15. Do you support regulating medium (0.75kW \leq x $<$ 185kW) and large three phase electric motors (185kW \leq x 375kW) at IE3 levels?
 16. Do you support adopting IE4 efficiency levels for the three phase electric motor in 2, 4, and 6 poles configuration in the range 75kW \leq x \leq 200kW levels?
- Implementation
 17. How much lead time would you consider is necessary to comply with an increasing of MEPS to IE3 levels for the current scope 0.75kW to 185kW? Note the proposed timeframe is 2027.
 18. How much lead time would you consider is necessary to comply with introducing MEPS at IE2 levels for small three phase electric motors 0.12 kW (inclusive) to 0.75kW? Note the proposed timeframe is 2027.
 19. How much lead time would you consider is necessary to comply with introducing MEPS at IE4 levels for three phase electric motor in 2, 4, and 6 poles configuration in the range 75kW \leq x \leq 200kW levels? Note the proposed timeframe is 2029.
- Registration

20. Do you support the proposal to change the family of model's definition for three phase electric motors? Do you have any feedback on the proposed definition e.g. should it include: shaft diameters and length requirements?
 21. Do you support a new requirement to provide an image of a motor's nameplate at point of registration and why?
- Labelling
 22. Do you support the introduction of product information requirements in line with EU eco-design 2019/1781 requirements Annex 1 point 2?
 23. Do you support the introduction of the requirement to display the current registration number of the three phase electric motor when offered for supply? Note this includes when a machine that contains a three phase electric motor is offered for supply.
 24. Do you think the existing nameplate requirements on three phase electric motor should be expanded to require a nameplate to be placed on a machine with the motor information, where the motor is not visible externally?
 - Compliance
 25. Is regulation of three phase electric motors and some products they are embedded into e.g. air conditioners and chillers an issue? If so, can you please explain in detail the issue you see.
 26. Do you have any suggestions on how compliance of three phase electric motors (including those embedded in or packaged with machinery) could be improved?

Appendix 1: Cost benefit approach and parameters

A financial analysis model has been built to review the overall costs and benefits related to each policy option. Proposals are compared to business as usual (BAU) where there is no change to the three phase electric motor's energy efficiency regulatory requirements. The approach to the cost benefit analysis has been conservative and the benefits are likely undercounted. The modelling in this CRIS includes the following benefits and costs:

Benefits

- Energy saving for consumers/the economy due to improved efficiency of three phase electric motors.
- Reduced emissions as a result of energy savings from policy.
- Regulatory benefits to industry and government including any saved administrative resources, test costs and registration costs resulting from changed regulatory settings.
- Peak demand reduction (minimal in this case).

Costs

- Higher capital cost of more energy efficient three phase electric motors.
- Regulatory costs to industry and government including any additional administrative resources resulting from changed regulatory settings.

Parameters and assumptions

Table 19: Primary modelling assumptions and parameters

Assumptions	Parameters
Scenarios	<ul style="list-style-type: none"> • BAU • Level 1: MEPS to be set at IE2 for 0.12 to <0.75 kW three phase electric motors, and IE3 for 0.75 to <375 kW three phase electric motors in 2027 • Level 2: MEPS to be set at IE2 for 0.12 to <0.75 kW three phase electric motors, IE3 for 0.75 to <75 kW three phase electric motors, IE4 for 75 to 200 kW three phase electric motors (2, 4, and 6 pole), and IE3 for greater than 200kW to < 375kW kW three phase electric motors in 2029
Sales	<ul style="list-style-type: none"> • Australian historical sales data based on limited industry-supplied data and Australian trade data from 1997 • New Zealand historical sales data based on EECA data • Forecast sales based on projected trends
Scope	The analysis presented has been based on the sales of bare three phase electric motors. Data on stock of three phase electric motors embedded in or packaged with machines is limited, and as such has been modelled as a sensitivity.
Stock	<p>Australian and New Zealand motor stock levels have been estimated by EnergyConsult using:</p> <ul style="list-style-type: none"> • In Australia, trade data for three phase electric motors net imports from 1997 • In New Zealand, EECA sales data collected from suppliers since 2003. <p>Motors are retired from the stock according to a survival function, with the average (50%) life of the different types of motors ranging from 10 to 25 years.</p>
Projection period	Impacts have been modelled to 2060 (installed stock to 2050)

Assumptions	Parameters
Industry costs	All incremental capital/development costs are assumed to be passed on to consumers
Product prices	Australia: Retail product prices were used New Zealand: Wholesale product prices were used It is assumed that IE3 motors generally cost 10% more than IE2 motors and this margin has been assumed in consultation with industry. It is assumed that IE4 motors generally cost 30% more than IE3 motors as a conservative assumption at the top end of the 22.5% to 30% premium range identified in the references.
Registration administration costs and compliance costs	<ul style="list-style-type: none"> Government administration costs are made up of salary, program administration and check testing Industry administration costs made up of time to complete registration, testing of products. As motors are already regulated for MEPS and labelling, only small increases in government costs are assumed in proportion to the increased scope of the various options
Energy consumption	<ul style="list-style-type: none"> Historic and future trends in energy efficiency for motors is based on the trends found by analysing the New Zealand EECA data over the last 15 years. The stock model used contains information on the numbers, capacity, efficiency and energy consumption of motors. Energy consumption estimates for the BAU baseline are established, and then the energy consumption under different policy options are calculated and compared to the BAU consumption. Products are retired from the stock according to a survival function which includes some early breakdowns, most motors retiring around the average and some motors having an extended life. Energy prices used are: <ul style="list-style-type: none"> Australia: based on state/territory electricity price index, from Australian Energy Market Operator (AEMO 2024), and Australian Competition and Consumer Commission, December 2023 (ACCC 2023). New Zealand: based on long-run marginal electricity cost (8.79 c/kWh) as advised by EECA, July 2024
GHG emissions	GHG emissions have been accounted for as CO ₂ equivalent units (CO ₂ -e) <ul style="list-style-type: none"> Australia: Projected factors from 2024 to 2035 - Australian Government³¹ by state and assumed to decline to close to zero from 2035 to 2050, as shown in Appendix 7. New Zealand: as advised by EECA July 2024.
Sensitivity analysis (NPV)	Australia: 7% real discount rate, with sensitivity tests at 0%, 3% and 10%. New Zealand: 5% real discount rate, with sensitivity tests at 0%, 2% and 7%.
Key assumptions	<ul style="list-style-type: none"> Reduction in energy use is due to new policy options described above. GHG abatements have been estimated and the financial/economic benefits of lower levels of greenhouse gas emissions have been quantified in the analysis, with sensitivity analysis conducted.

³¹ Department of Climate Change, Energy, the Environment and Water (DCCEEW), 2023

Table 20: Assumptions used in analysis of secondary options

Scenarios:	Registration changes: changes to families of models that will allow suppliers to register from 2 to 10 models on a single registration; and to include a photo of the motor nameplate with registration.
	Labelling changes: Registration number and technical information to be included on motor documents, supplier website and technical data sheet.

Table 21: Primary modelling assumptions and parameters continued

Item	Quantity	Reference/comment
Additional cost per picture of nameplate	\$43 per motor registered	Based on ½ hr per motor @\$85 per hour as per OIA 2024 ³²
Value of industry/Government staff time	\$85 per hour	OIA 2024
Unit cost for changes to technical data sheets	\$170 per registration	Based on 2 hrs per data sheet
Number of new motor registrations	952 per annum	Average over last ten years
Saving in annual motor testing/administration cost by industry	\$308,500	10% of current annual cost of \$3.085m (0.75 – 40 kW range)
Reduced Government compliance effort	200 hours per annum @\$85	Estimate agreed with EECA
% of motor registrations incurring no additional data sheet cost as they are already sold in the EU	40%	Estimate

Calculation of sales and stock

Australian Sales

Sales are based on import and export data in Australia 1997 – 2019, to obtain net imports (DFAT 2020). It is assumed that net imports of bare motors represent the number of motors installed in Australia. The import data were divided into 6 size categories, as follows:

- Size 0: $\geq 0.0375\text{kW} < 0.75\text{kW}$
- Size 1: $\geq 0.75\text{kW} < 3.0\text{kW}$
- Size 2: $\geq 3.0 < 7.46\text{kW}$
- Size 3: $\geq 7.46 < 75\text{kW}$
- Size 4: $\geq 75\text{kW} < 132\text{kW}$
- Size 5: $\geq 132\text{kW}$

There is considerable variation in net imports by category over this period as shown in Figure 6.

³² Office of Impact Analysis, 2024

Figure 6: Annual net imports from Australian trade data by size category

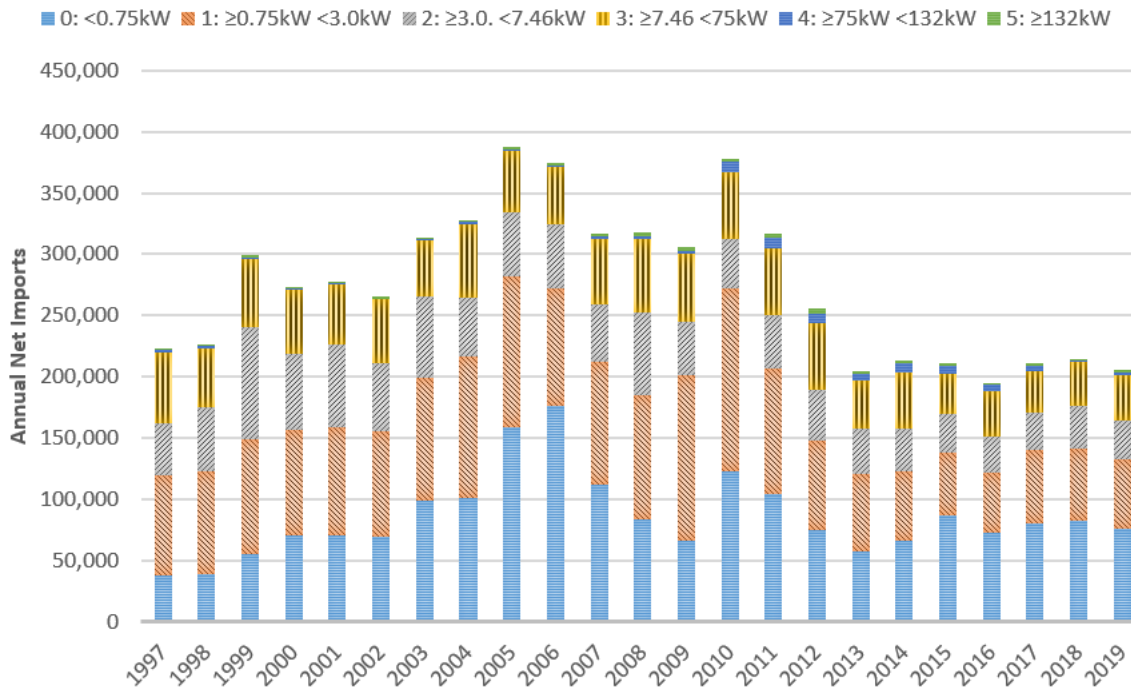

To derive the sales by MEPS category, the share of sales by MEPS category of motors from the survey of Australian suppliers³³ was used to segment the trade data categories into MEPS categories. The survey data was found to represent about 40% of total net imports in 2019, which considering the companies that responded, provided a representative sample to enable this re-categorisation.

Forecast sales are based on historical trends to 2019 for each MEPS category, with the starting trend year chosen to reflect realistic later decade trends (i.e. generally from 2014 to 2019). For example, category 2: 0.73-<4kW, shown in Figure 7 used the historical sales from 2014 to 2019 as the input data.

³³ Confidential surveys were undertaken with Australian motor industry stakeholders during 2020, and these were completed by companies responsible for around 40% of the motors sold in 2019.

Figure 7: Example of historical and forecast sales of category (2: 0.73-<4kW)

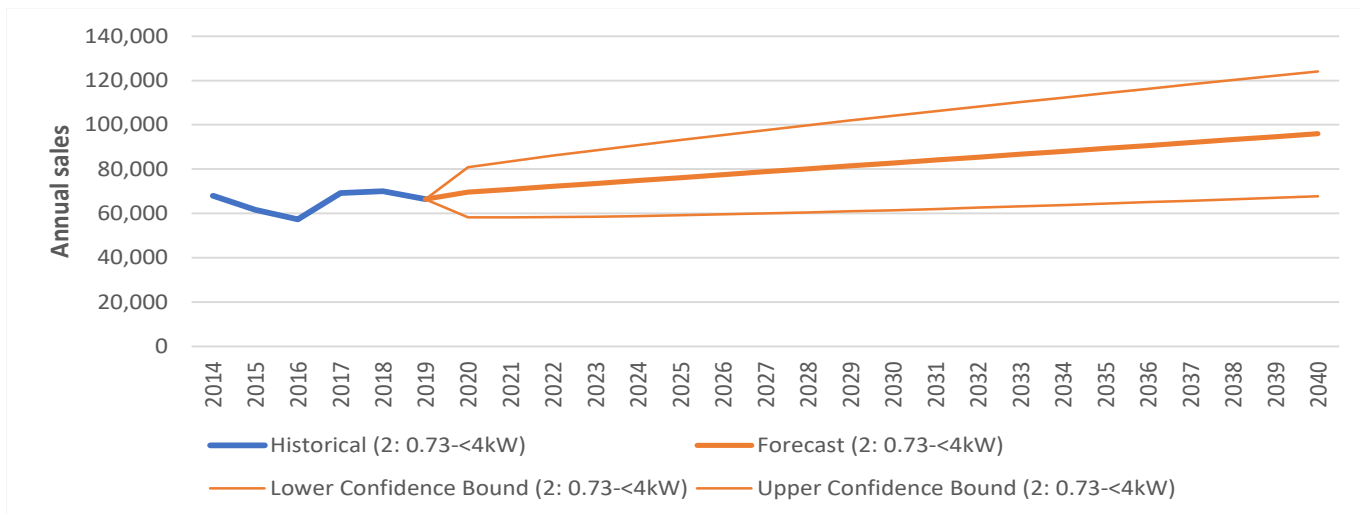

New Zealand Sales

The sales by MEPS category were based on EECA sales data 2009 to 2023 (earlier years were not segmented by category). The estimated sales by size category for the historical years is shown in Figure 8. The EECA sales data was categorised by size for those segments covered by the MEPS, and estimated in proportion to the shares by sales category for Australia for those categories not included in the EECA sales data (i.e. sizes 0.12-<0.73kW and > 185kW).

Figure 8: Annual net sales by size category New Zealand

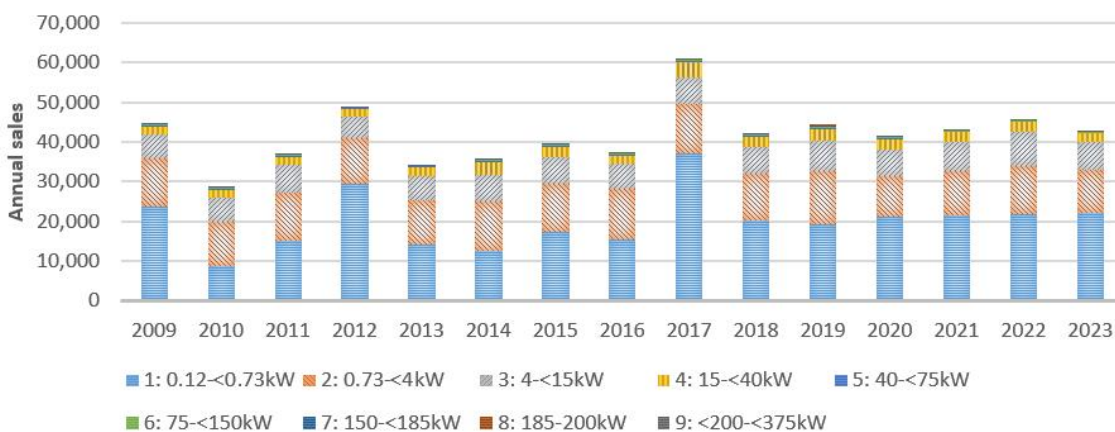

The forecast sales are based on historical trends from 2009 to 2023 for each MEPS category.

Stock and energy modelling approach

The stock model used for the modelling is effectively a database that keeps a running tally of the numbers of each product in the stock in any year, and the average characteristics of each product in any

year. The stock in any year is the sum of all past sales, less retirements of equipment at their end of life, and the sales of new equipment in that year.

Figure 9 provides a graphic illustration of how the stock model works. It shows that the product stock is added to by the cohort of sales in each year, and these products remain part of the stock into the future, but gradually reduce in number as they are retired. If the average energy efficiency of the products sold from a particular date increases as a result of the policy options modelled, these efficiency improvements will gradually flow through the entire stock so that overall it becomes more efficient than in the BAU scenario.

Figure 9: Example - graphic representation of stock model

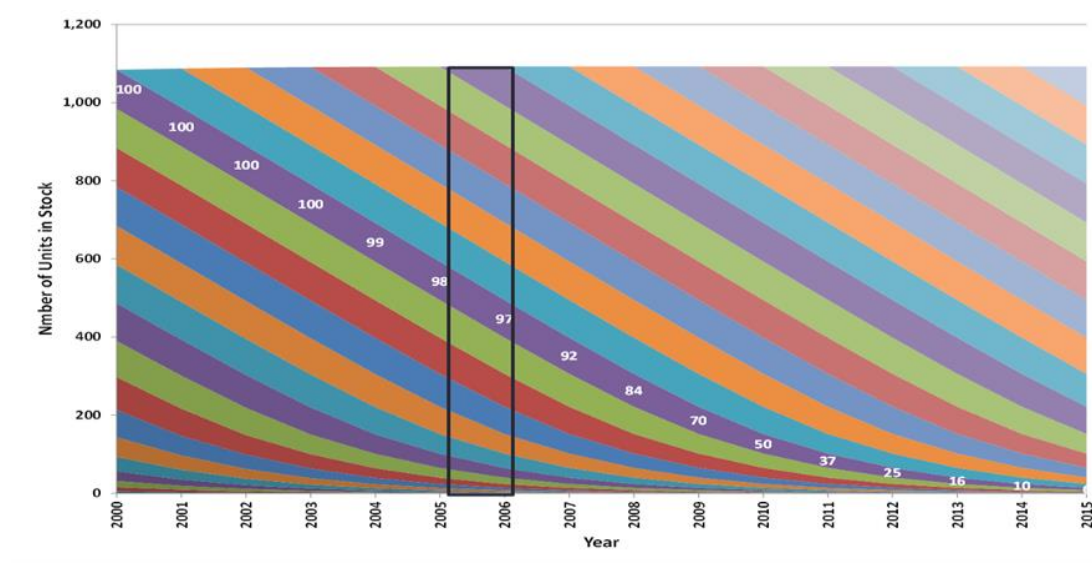

In each year the new cohort of products entering the stock are subjected to appropriate “survival functions” for each category. Examples of the different survival functions are shown in Figure 10 and Figure 11 where a graphical view is presented of the percentage of motors (R_t) in useful service over the life in years from purchase (t). As can be seen from Figure 9 a considerable proportion of each cohort remains in place well after the half-life date.

Figure 10: Examples of survival functions 20-year half life

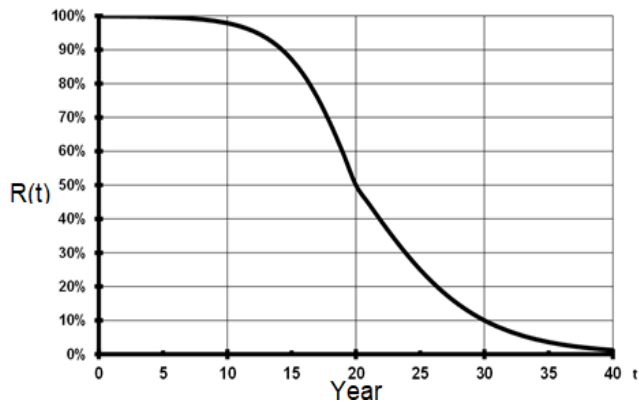
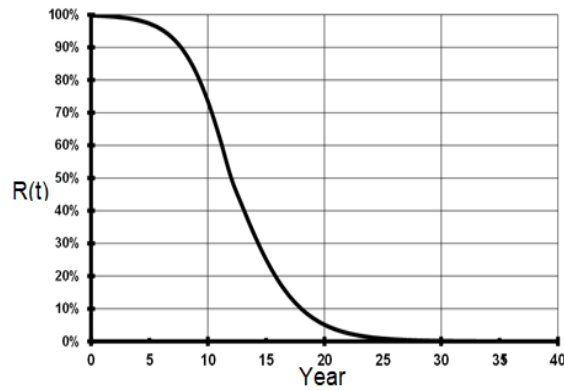

Figure 11: Examples of survival functions 12-year half life



The IEA 4E, 2015 report estimates the average expected life of motors by size based on a sample of over 4,000 motors. This data was used to estimate the half-life, in years, of the motors by size category as shown in the table below:

Table 22: Expected half-life for motors by size category

Size Category	1: 0.12- <0.73kW	2: 0.73- <4kW	3: 4- <15kW	4: 15- <40kW	5: 40- <75kW	6: 75- <150kW	7: 150- <185kW	8: 185- 200kW	9: >200- <375kW
Life (Years) used in Model (50% life)	10	12	12	15	15	20	20	20	25
Life (Years) from IEA 4E (2015)	10	12	15	15	15	15-20	20	20	20

Other factors related to stock modelling

The stock is calculated from the sales inputs and life assumptions as described earlier (Table 19). There is a requirement for the energy modelling to separate the installations attributed to the industrial sector and commercial sector as the hours of operation are typically different. The proportion of sales attributed to the industrial sector is estimated for each size category. As the majority of three phase electric motors are utilised in the industrial sector (Pitt & Sherry, 2009), the assumptions provided in Table 23 are used. Commercial sector shares are found by deducting the industry share (e.g. 100% minus 80% industry share leaves 20% commercial share). It is assumed that generally, very few motors of larger size are installed in the commercial sector. However, in the smallest size range (0.12 - <0.73 kW), three phase motors are mostly used in industry (conveyors, chemical processes, machinery, etc).

Table 23: Share of sales attributed to industrial sector (Australia and New Zealand)

Size/ Poles	1: 0.12- <0.73kW	2: 0.73- <4kW	3: 4- <15kW	4: 15- <40kW	5: 40- <75kW	6: 75- <150kW	7: 150- <185kW	8: 185- 200kW	9: >200- <375kW
2	80%	60%	70%	80%	85%	90%	100%	100%	100%
4	80%	60%	70%	80%	85%	90%	100%	100%	100%

Size/ Poles	1: 0.12- <0.73kW	2: 0.73- <4kW	3: 4- <15kW	4: 15- <40kW	5: 40- <75kW	6: 75- <150kW	7: 150- <185kW	8: 185- 200kW	9: >200- <375kW
6	80%	60%	70%	80%	85%	90%	100%	100%	100%
8	80%	60%	70%	80%	85%	90%	100%	100%	100%

In addition, the energy modelling assumes that the motor is installed and operating, however there is typically a proportion of motors that are sold, but not installed immediately, and kept as spares in case of breakdowns or held in stock (in the case of using import trade data). Therefore, to model the operating motors, an assumption is also made that effectively reduces the import/sales number of motors. The share of motor sales held in storage would be expected to be higher for smaller, less costly motors and virtually zero for larger motors. The assumed share of sales held in store is estimated to be 20% for Size 1: 0.12-<0.73kW, decreasing to 0% for motors greater than 150 kW.

Australian stock

The resulting Australian stock of motors by size category and year is shown in Figure 12. It is noted that the overall stock is increasing until 2012 and then declining until 2030 with a slight increase over the next decade. This is largely due to the rapid increase in the period 2000 to 2012 of motors under 4kW. We are interested in stakeholder feedback on the reasons for this.

Figure 12: Estimated stock by size category by year (historical to 2019, forecast post 2020): Australia

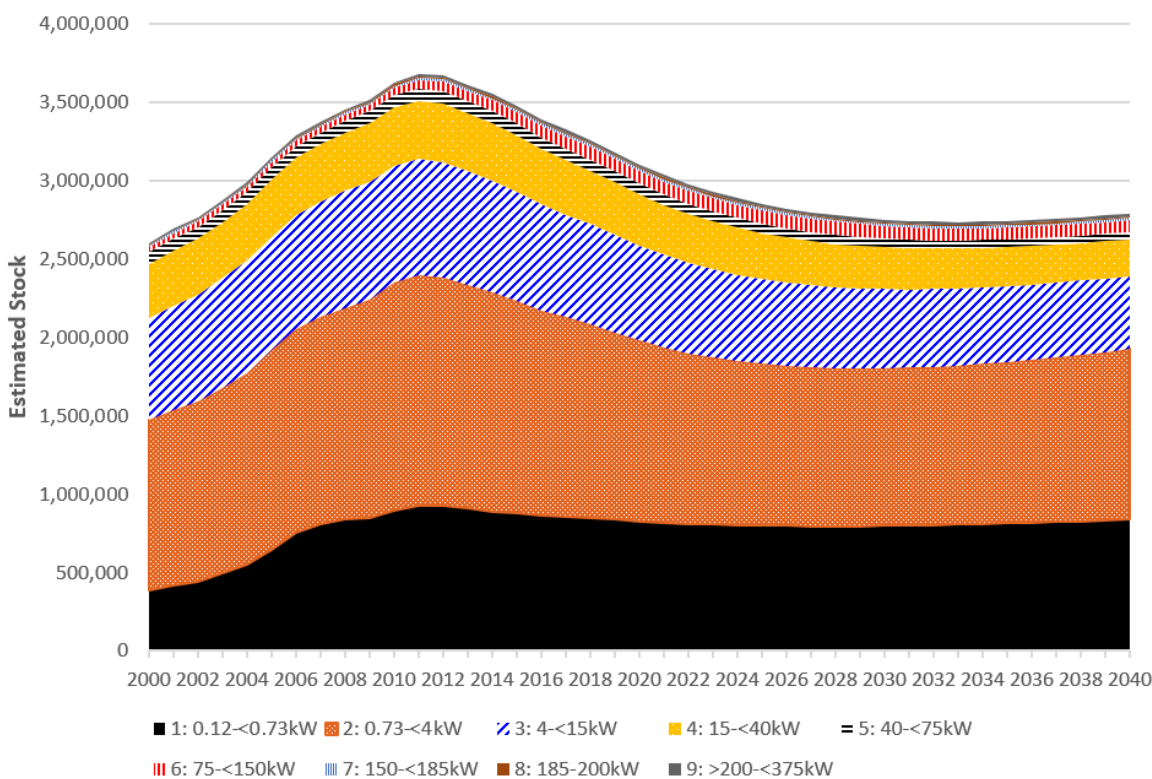

New Zealand Stock

The estimated stock of motors in New Zealand is shown in Figure 13. The overall growth of stock is increasing.

Figure 13: Estimated stock by size category by year (historical to 2020, forecast post 2020): New Zealand

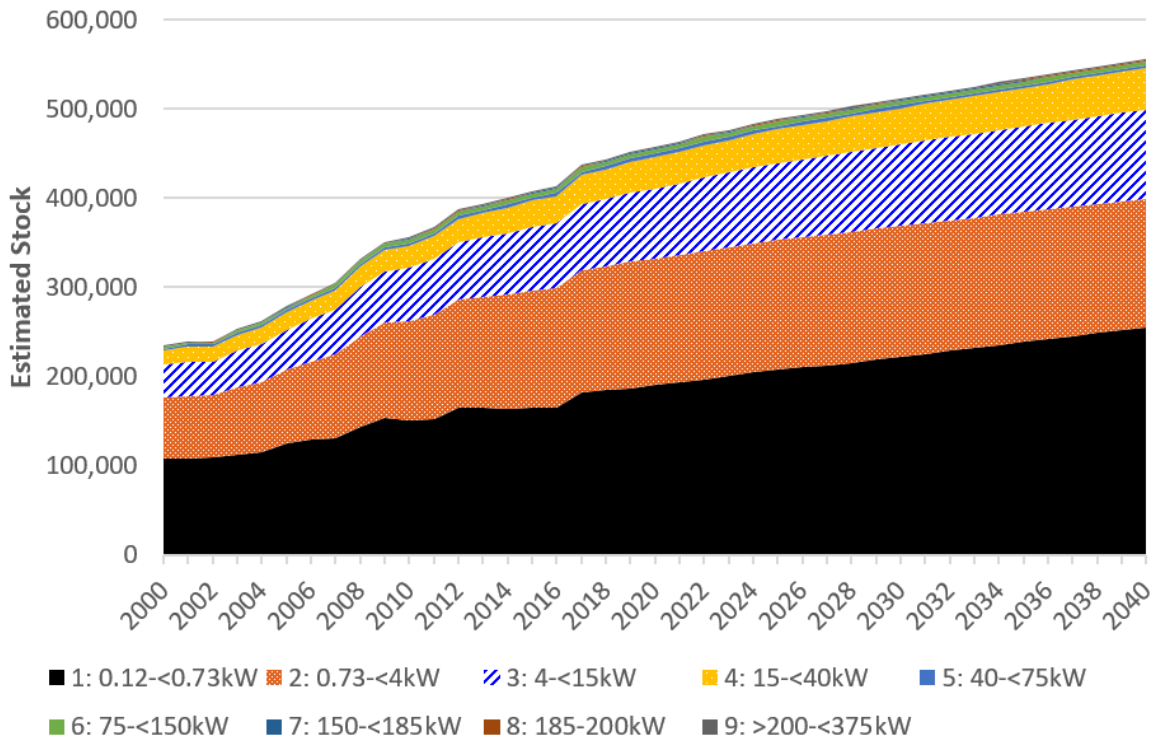

Calculation of energy consumption

The energy consumption of motors is calculated using an international approach (EU, 2019), as follows:

$$\text{Energy use (kWh)} = \text{Output Power (kW)} * \text{Hours} * \text{Load factor} / (\text{motor efficiency}).$$

Where:

- *Output power* is the average sales weighted output power for each size category/poles
- *Hours* is the estimated annual operating hours for category and sector
- *Load factor* is estimated to be 0.6 for all categories (EU, 2019)
- *Motor efficiency* is the average sales weighted efficiency for each size category/poles, at 75% load, when measured using IEC 60034-2-1 Ed. 2.0 test standard (Method 2-1-1B) or equivalent.

Values for average output power are shown in Table 24. These are derived from the average sales weighted output power for each size of motor by category and pole sold in Australia and New Zealand.

Table 24: Average output power by size category and poles (kW)

Size/Poles	1: 0.12-<0.73kW	2: 0.73-<4kW	3: 4-<15kW	4: 15-<40kW	5: 40-<75kW	6: 75-<150kW	7: 150-<185kW	8: 185-200kW	9: >200-<375kW
2	0.4	1.8	6.7	21.3	49.7	89.6	154.6	194.8	277.7

Size/Poles	1: 0.12- <0.73kW	2: 0.73- <4kW	3: 4- <15kW	4: 15- <40kW	5: 40- <75kW	6: 75- <150kW	7: 150- <185kW	8: 185- 200kW	9: >200- <375kW
4	0.4	1.6	6.5	22	49.9	93	153.4	192.1	276.4
6	0.4	1.6	6.5	23.5	50.7	91.2	155.1	188.3	272.1
8	0.4	1.7	7.2	21.8	49.4	95.6	150.0	198.8	232.0

The average hours of operation are estimated from similar motor MEPS impact studies in the EU (EU, 2019, University of Coimbra, 2008) and adjusted so that energy outputs are reconciled with total estimated energy consumption by sector in Australia and New Zealand. The average annual operating hours by size category and sector are shown in Table 25. The average load factor was set to 0.6, based on the similar motor MEPS impact studies in the EU (EU, 2019, University of Coimbra, 2008).

Table 25: Average hours of operation by size category and sector (annual hours)

Size Category	1: 0.12- <0.73kW	2: 0.73- <4kW	3: 4- <15kW	4: 15- <40kW	5: 40- <75kW	6: 75- <150kW	7: 150- <185kW	8: 185- 200kW	9: >200- <375kW
Industry	2000	2800	2800	3500	3500	4000	4000	4000	4000
Commercial	2000	2000	2000	2000	2000	2000	2000	2000	2000

Three phase electric motor efficiency is determined by analysis of the New Zealand sales data from EECA (2009 -2023) and compared to the results of similar analysis of motor sales survey data for Australia (2019 year).³⁴ The analysis involved:

- Using the 75% load efficiency, as this is closest to the load used for modelling energy consumption
- Converting efficiency of motors measured using Australian Standard method B to method A³⁵
- Using the sales to weight the efficiency for each motor size and combining sizes to calculate the average efficiency for each category.

The BAU average sales weighted efficiency for each category and by pole is shown in Table 26 for 2023 and is derived from EECA sales data. The survey data from Australian suppliers was used for the categories that are not included in the EECA sales data (i.e. sizes 0.12-<0.73kW and > 185kW). The annual BAU efficiency improvement over the last five years for each of the categories is very small based on the EECA data, ranging from -0.22% to 0.26% per annum (CAGR). For modelling future annual improvements in efficiency, the values for the last three years were used, except those with negative improvement were set to zero percentage change.

³⁴ Confidential surveys were undertaken with motor industry stakeholders during 2020, and these were completed by companies responsible for around 40% of the motors sold in 2019.

³⁵ The Regulations before the 2019 Determination referred to local Australian and New Zealand Standards. AS/NZS 1359.102.3 and AS 1359.102.1

Table 26: Average efficiency by size category and poles (75% load)

Size/Poles	1: 0.12- <0.73k W	2: 0.73- <4kW	3: 4- <15kW	4: 15- <40kW	5: 40- <75kW	6: 75- <150k W	7: 150- <185kW	8: 185- 200kW	9: >200- <375k W
2	70.58%	85.00%	89.80%	92.66%	94.28%	94.95%	95.01%	95.54%	95.58%
4	69.77%	84.74%	89.60%	93.21%	94.73%	95.36%	96.33%	95.86%	95.86%
6	66.60%	81.79%	88.44%	92.61%	94.35%	95.72%	95.93%	95.81%	95.96%
8	58.02%	78.34%	89.81%	91.20%	93.50%	95.50%	94.19%	94.25%	94.69%

Average efficiency increase due to policy options

In practice, as there is a range of motor efficiencies available for each motor size/type, the average efficiency of the motors sold is likely to be higher than the minimum efficiency levels specified. For the cost-benefit modelling, the sales-weighted efficiency for each product category has been determined by a proportional relationship based on the difference of the MEPS efficiency levels compared to the BAU efficiency levels. This increase is based on how stringent the MEPS efficiency level is compared to the BAU efficiency. The cost-benefit model calculates the difference and utilises a normal distribution function to calculate the effect of the MEPS. This methodology ensures that average efficiency increases account for the likely realistic impact of the policy options for each motor category. Using this method, the absolute sales weighted average motor efficiency above the MEPS level (IE3) ranges from 0.5% for size category 1 (0.73- 4kW) to less than 0.2% for size category 9 (200-375 kW).

Average motor cost increase due to policy options

A key input for the modelling of the costs of the proposed policy options is the impact of the options on the price of the product to the buyer. The assumption used in the modelling is that more efficient equipment is more expensive than a similar performing product with lower efficiency. This approach has been used for past RISs to determine the relative costs of the efficiency improvements due to the policy options modelled.

A range of options exists for determining the potential price changes as a result of the policy options, such as engineering/cost deconstruction, surveys of the suppliers to obtain price increments vs efficiency performance, analysis of the price vs efficiency relationship from model prices and technical data. The latter two approaches were used in this modelling exercise. The aim of this price vs efficiency research is to obtain a value for the price efficiency (PE) ratio that can be used to assess the cost impacts of the policy option, such as every 1% increase in the average efficiency of the products being sold/installed the average price increases by 1.0% (a PE ratio of 1.0).

In consultation with motor suppliers, it has been assumed that the average increase in price is 10% for a motor when choosing an IE3 motor compared to an IE2 motor. This incremental price increase is the basis of the input for the cost benefit modelling. To obtain the inputs for the modelling, the PE ratio will vary depending on size of the incremental efficiency change from IE2 to IE3. The analysis shows that the smaller the incremental difference, using a constant 10% price increase, the larger the PE ratio. This is expected, as the IE3/IE2 difference decreases for larger sizes of motors. For example, the PE ratio that

results from a 10% increase (IE3 vs IE2) is 3.2 for size category 1 (0.73- 4kW) to 10.5 for size category 9 (250-375 kW).

For the option of increasing MEPS to IE4, the average price is assumed to increase by 30%, which is based on the average price increase for motors from IE3 to IE4 for the size range 75 – 200 kW from a UK published price list³⁶. This average price increase is higher than that used in the EU study of 22.5%.

Where the proposed policy options resulted in an increase in the average efficiency of motors sold compared to BAU, the PE ratio was applied to the prices shown in Table 27 to calculate the average purchaser price increase for these motors.

Table 27: Average purchaser price by size category and poles (AUD)

Size/Poles	1: 0.12- <0.73kW	2: 0.73- <4kW	3: 4- <15kW	4: 15- <40kW	5: 40- <75kW	6: 75- <150kW	7: 150- <185kW	8: 185- 200kW	9: >200- <375kW
2	\$119	\$270	\$719	\$1,702	\$3,292	\$5,838	\$11,011	\$12,019	\$19,327
4	\$122	\$310	\$697	\$1,852	\$3,541	\$6,466	\$10,740	\$12,371	\$18,829
6	\$160	\$378	\$960	\$2,421	\$4,921	\$10,638	\$16,036	\$20,092	\$23,418
8	\$335	\$822	\$2,088	\$4,544	\$9,772	\$21,710	\$30,496	\$37,647	\$41,647

Source: Supplier survey and published prices (AIM 2020). For New Zealand, the EECA-provided exchange rate A\$1=NZ\$1.08 is assumed.

Government and industry costs

The costs to government and industry for these policy options are described below. For both levels there is an assumed establishment cost to government of \$250,000, which includes research, consultation, survey, analysis and revisions to the GEMS legislation/implementation procedures.

Level 1: Increase scope to cover motors from 0.12 kW to <375 kW; with MEPS set at IE2 for 0.12 to <0.75 kW motors and IE3 for 0.75 to <375 kW motors.

Under this option, there will be additional government and industry costs as the scope is changed.

The government costs include additional administration and check testing. The industry costs are described in Table 28. The additional costs are:

- No additional education costs, as it is assumed the same motor suppliers included in the scope of Level 1 will be supplying the motors included in the scope of Level 2
- There are additional testing costs as it is assumed a proportion of motors supplied in the new scope are not supplied in the EU or US.
- The additional permission costs (those to complete registration) are estimated at \$43 per model for those registered.
- The additional permission costs (registration fee) are as published by the GEMS Regulator A\$670 per model registered for those in the scope of the option.

³⁶ AC electric motors, 2024

Level 2: MEPS set at IE4 for 75 kW (inclusive) to 200 kW (inclusive) motors.

It is assumed that there are no incremental government costs in addition to the existing MEPS program as the scope is not changing. Similarly, there are no industry costs, as suppliers are already required to register these products within the scope.

For Level 1, the industry costs are the registration fees, testing of motors that have not already been tested, and the effort/time costs of submitting registrations, maintaining records and keeping up to date with regulatory requirements. These costs are calculated on the following basis:

Table 28: Government and industry costs (AUD\$)

Costs	Level 1	Level 2
Government costs		
Administration	\$100,000 p.a.	Included in Level 1.
Check testing	\$100,000 p.a.	Included in Level 1.
Industry costs		
Education - Train staff, keep up-to-date with regulations (per supplier)	\$6,814	Included in Level 1.
Record Keeping - Maintain documents for five years (per supplier)	\$681	Included in Level 1.
Permission - Test product in laboratory (per model varies see below)	Assume that 30% of models will need to be tested in the 0.12 kW to <0.75 kW category and all models over 185 kW will be tested already for EU and USA markets	Included in Level 1.
Permission - Complete MEPS registration (per model)	\$170	Included in Level 1.
Permission - Registration fee (per model)	\$536 (based on 80% of the fee, assuming 20% are registered in New Zealand)	Included in Level 1.

Data on the number of companies and the number of motors models on the market was obtained from the E3 registration database. For costing purposes it has been assumed that only models that would be impacted by the increased scope of MEPS policy options would incur costs. For the new scope this means that approximately 2,000 models are estimated to be registered in the first year and then 400 models are registered per year for Level 1.

Timeframe and discount rates

It is assumed that Level 1 policy options will be introduced in 2027 and Level 2 options in 2029, with the expected date for calculating impacts beginning in 2027 and 2029 respectively.

All the outputs in the cost-benefit analysis were assessed in Australia at a 7% discount rate, with sensitivity tests at 0%, 3% and 10%. For New Zealand a 5% discount rate is used, with sensitivity tests at 0%, 2% and 7%.

Electricity prices

The electricity prices and forecasts used in the modelling are taken from documented research:

In Australia they are based on Large Business Customers electricity price from the ACCC³⁷ and the forecast is made using the wholesale price index, from AEMO 2024 Draft ISP (Step change scenario)³⁸.

In New Zealand electricity prices are the long range marginal cost provided by the Energy Efficiency and Conservation Authority.

Greenhouse gas emission factors

The GHG emission factors and forecasts used in the modelling are taken from published sources³⁹, with the Australian factors assumed to decline to close to zero over the period from 2035 to 2050. The New Zealand factors are sourced from EECA in 2024, and based on the scenarios produced by the Climate Change Commission's 2021 Final Advice⁴⁰.

Value of greenhouse gas emissions avoided

The benefits include a value for the reduction of Greenhouse Gas Emissions in accordance with CBA methodologies. The emissions reduction value is calculated by multiplying the carbon reduction by the carbon price in each year. For Australia, the carbon price ranges from \$70/tonne in 2024 to \$420/tonne in 2050 (AUD\$ real, AEMC 2024), and in New Zealand, the carbon price ranges from \$105/tonne in 2024 to \$309/tonne in 2050 (New Zealand Treasury 2023, New Zealand dollars real, central scenario).

Sensitivity tests are undertaken as follows:

Australia: Zero, and 50% lower and 50% higher than the central carbon price⁴¹.

New Zealand: Zero, low and high recommended emission values⁴².

Peak demand reduction

The estimated peak demand reduction from the above options is 48 MW in Australia and 5 MW in New Zealand in 2050. These values are minimal compared to the energy savings and, hence, have not been quantified in the CBA, but are provided here for context.

³⁷ Australian Competition and Consumer Commission (ACCC), 2023

³⁸ Australian Energy Market Operator (AEMO), 2023

³⁹ Department of Climate Change, Energy, the Environment and Water (DCCEEW), 2023

⁴⁰ New Zealand Climate Change Commission, 2021

⁴¹ Australian Energy Market Commission (AEMC), 2024

⁴² New Zealand Treasury, 2023

Appendix 2: Sensitivity analysis

The CBA is based on a number of assumptions, which can be sensitive to change. Several sensitivity analyses were undertaken to examine the impact of various factors on the costs and benefits arising from the modelling. These sensitivity analyses were:

- Discount rate
- Carbon price
- Three phase electric motors embedded or packaged with machines
- Non-compliant motors

The various discount rates impact the cost benefit ratios, total benefits, and total costs. The highest discount rate for both Australia and New Zealand results in the lowest benefit, lowest cost, and lowest benefit to cost ratio, but these are still substantial.

Table 29: Discount rate sensitivity analysis – Australia Discount rate (real) – Level 1

Discount rate (real)	0 per cent	3 per cent	7 per cent	10 per cent
Level 1				
Total Benefits (NPV, \$M)	\$947	\$504	\$243	\$152
Total Costs (NPV, \$M)	\$126	\$83	\$52	\$38
Net Benefits (NPV, \$M)	\$821	\$420	\$192	\$114
Benefit Cost Ratio	7.5	6.0	4.7	4.0

Table 30: Discount rate sensitivity analysis – Australia Discount rate (real) – Level 2

Discount rate (real)	0 per cent	3 per cent	7 per cent	10 per cent
Level 2				
Total Benefits (NPV, \$M)	\$1,346	\$704	\$333	\$205
Total Costs (NPV, \$M)	\$275	\$177	\$106	\$75
Net Benefits (NPV, \$M)	\$1,071	\$527	\$227	\$129
Benefit Cost Ratio	4.9	4.0	3.1	2.7

Table 31: Discount rate sensitivity analysis – New Zealand Discount rate (real) – Level 1

Discount rate (real)	0 per cent	3 per cent	7 per cent	10 per cent
Level 1				
Total Benefits (NPV, \$M)	\$88	\$57	\$32	\$22
Total Costs (NPV, \$M)	\$11	\$8	\$6	\$5
Net Benefits (NPV, \$M)	\$77	\$49	\$26	\$18
Benefit Cost Ratio	7.9	6.8	5.5	4.9

Table 32: Discount rate sensitivity analysis – New Zealand Discount rate (real) – Level 2

Discount rate (real)	0 per cent	3 per cent	7 per cent	10 per cent
Level 2				
Total Benefits (NPV, \$M)	\$103	\$67	\$37	\$26
Total Costs (NPV, \$M)	\$15	\$11	\$8	\$6
Net Benefits (NPV, \$M)	\$88	\$55	\$29	\$20
Benefit Cost Ratio	6.8	5.9	4.8	4.2

Table 33: Carbon price sensitivity analysis – Australia (Discount rate 7% real) – Level 1

	None	Low	Central	High
Level 1			(Base Case)	
Total Benefits (NPV, \$M)	\$212	\$228	\$243	\$259
Total Costs (NPV, \$M)	\$52	\$52	\$52	\$52
Net Benefits (NPV, \$M)	\$160	\$176	\$192	\$207
Benefit Cost Ratio	4.1	4.4	4.7	5.0

Table 34: Carbon price sensitivity analysis – Australia (Discount rate 7% real) – Level 2

	None	Low	Central	High
Level 2				
Total Benefits (NPV, \$M)	\$289	\$311	\$333	\$354
Total Costs (NPV, \$M)	\$106	\$106	\$106	\$106
Net Benefits (NPV, \$M)	\$183	\$205	\$227	\$249
Benefit Cost Ratio	2.7	2.9	3.1	3.4

Table 35: Carbon price sensitivity analysis – New Zealand (Discount rate 5% real) – Level 1

	None	Low	Central	High
Level 1			(Base Case)	
Total Benefits (NPV, \$M)	\$28	\$31	\$32	\$33
Total Costs (NPV, \$M)	\$6	\$6	\$6	\$6
Net Benefits (NPV, \$M)	\$22	\$25	\$26	\$27
Benefit Cost Ratio	4.9	5.3	5.5	5.8

Table 36: Carbon price sensitivity analysis – New Zealand (Discount rate 5% real) – Level 2

	None	Low	Central	High
Level 2				
Total Benefits (NPV, \$M)	\$33	\$36	\$37	\$39
Total Costs (NPV, \$M)	\$8	\$8	\$8	\$8
Net Benefits (NPV, \$M)	\$25	\$28	\$29	\$31
Benefit Cost Ratio	4.2	4.6	4.8	5.0

As stated in Appendix 1: Cost benefit approach and parameters, the analysis has focused on bare three phase electric motors due to the limited data available on three phase electric motors incorporated into a machine (embedded in or packaged with). The majority of three phase electric motors, approximately

65% according to an analysis of Australian 2021 import data⁴³, will be imported as part of an integrated product or as part of an item of equipment as shown in Figure 14.

It is considered that the best modelling approach to three phase electric motors embedded in or packaged with three phase electric motors is to carry out a sensitivity analysis on the potential impact of policy options.

Key assumptions used in this sensitivity analysis are:

- Three phase electric motor sales embedded in or packaged with machines are two times the sales of bare three phase electric motors
- The models that are not currently registered will incur three times the administrative burden of bare three phase electric motor registration (testing, time to complete registration, etc)
- This results in a multiplier of six times the number of bare motor models registered.
- To ensure a conservative approach is taken, there are no benefits claimed for these three phase electric motors.

Table 37: Embedded motors sensitivity analysis – Australia and New Zealand – Level 1

	Australia		New Zealand	
	Embedded Motors Scenario	Base Case	Embedded Motors Scenario	Base Case
Level 1				
Total Benefits (NPV, \$M)	\$243	\$243	\$32	\$32
Total Costs (NPV, \$M)	\$90	\$52	\$15	\$6
Net Benefits (NPV, \$M)	\$154	\$192	\$17	\$26
Benefit Cost Ratio	2.7	4.7	2.1	5.5

Australia discount rate is 7%, New Zealand discount rate is 5%

Table 38: Embedded motors sensitivity analysis – Australia and New Zealand – Level 2

	Australia		New Zealand	
	Embedded Motors Scenario	Base Case	Embedded Motors Scenario	Base Case
Level 2				
Total Benefits (NPV, \$M)	\$333	\$333	\$37	\$37
Total Costs (NPV, \$M)	\$144	\$106	\$17	\$8
Net Benefits (NPV, \$M)	\$189	\$227	\$20	\$29
Benefit Cost Ratio	2.3	3.1	2.2	4.8

Australia discount rate is 7%, New Zealand discount rate is 5%

As can be seen from the table above, the benefit cost ratio reduces by 25% for Australia and 55% for New Zealand when making the above-mentioned assumptions regarding three phase electric motors embedded in or packaged with machines for Level 2.

⁴³ EnergyConsult, 2023

There is also uncertainty about the effect of non-compliant three phase electric motors that are imported and used in Australia and New Zealand. It is known that there is non-compliance with the energy efficiency requirements for three phase electric motors, but the extent cannot be confidently quantified. There is no certainty that 100% compliance with a higher (IE3 or IE4) MEPS could be enforced. To understand the impact of non-compliance an assumed 10% non-compliance is shown below. This reduces the costs and benefits by 10%.

Table 39: Non-compliant motors sensitivity analysis - Australia and New Zealand – Level 1

	Australia		New Zealand	
Level 1	10% non-compliance	Base Case	10% non-compliance	Base Case
Total Benefits (NPV, \$M)	\$219	\$243	\$29	\$32
Total Costs (NPV, \$M)	\$47	\$52	\$5	\$6
Net Benefits (NPV, \$M)	\$172	\$192	\$23	\$26
Benefit Cost Ratio	4.7	4.7	5.5	5.5

Australia discount rate is 7%, New Zealand discount rate is 5%

Table 40: Non-compliant motors sensitivity analysis - Australia and New Zealand – Level 2

	Australia		New Zealand	
Level 2	10% non-compliance	Base Case	10% non-compliance	Base Case
Total Benefits (NPV, \$M)	\$299	\$333	\$33	\$37
Total Costs (NPV, \$M)	\$95	\$106	\$7	\$8
Net Benefits (NPV, \$M)	\$204	\$227	\$26	\$29
Benefit Cost Ratio	3.1	3.1	4.8	4.8

Australia discount rate is 7%, New Zealand discount rate is 5%

Appendix 3: Motor energy use by sector and end use

Electric motors account for a large share of electricity consumption in Australia and New Zealand using an estimated 47% and 43% of total electricity demand across Australia and New Zealand.

It is estimated that around 80% of this electricity consumption by motors is from three phase motors, with the remaining 20% consumed by smaller, but more numerous, single-phase motors in both markets. Three phase electric motors and systems are estimated to account for 38% and 34% of electricity use in Australia and New Zealand respectively.

Fans, pumps and compressors use about 75% of the electricity consumption of three phase motors in Australia, as shown in Table 41 below:

Table 41: Product's share of motors' electricity consumption⁴⁴

Product	Share
Pumps	40%
Fan units	20%
Compressors	15%
Conveyors	15%
Miscellaneous	10%

Source: Industry consultation for Consultation RIS by E3 for Australia and New Zealand, 2019

The distribution of three phase motors into different applications is shown in Figure 14 for 2021 imports to Australia, and clearly shows the different role bare motors play in three phase motor imports, with over a third of motors arriving as bare motors. Fans, machines, pumps and air compressors dominate the applications where three phase motors are imported as part of equipment. Though the motors of these systems will be required to meet MEPS requirements, the overall products/systems are not regulated under GEMS.

⁴⁴ Data is for three phase electric motors in Australia, but believed to be similar for New Zealand

Figure 14: Three phase electric motor imports, Australia by application

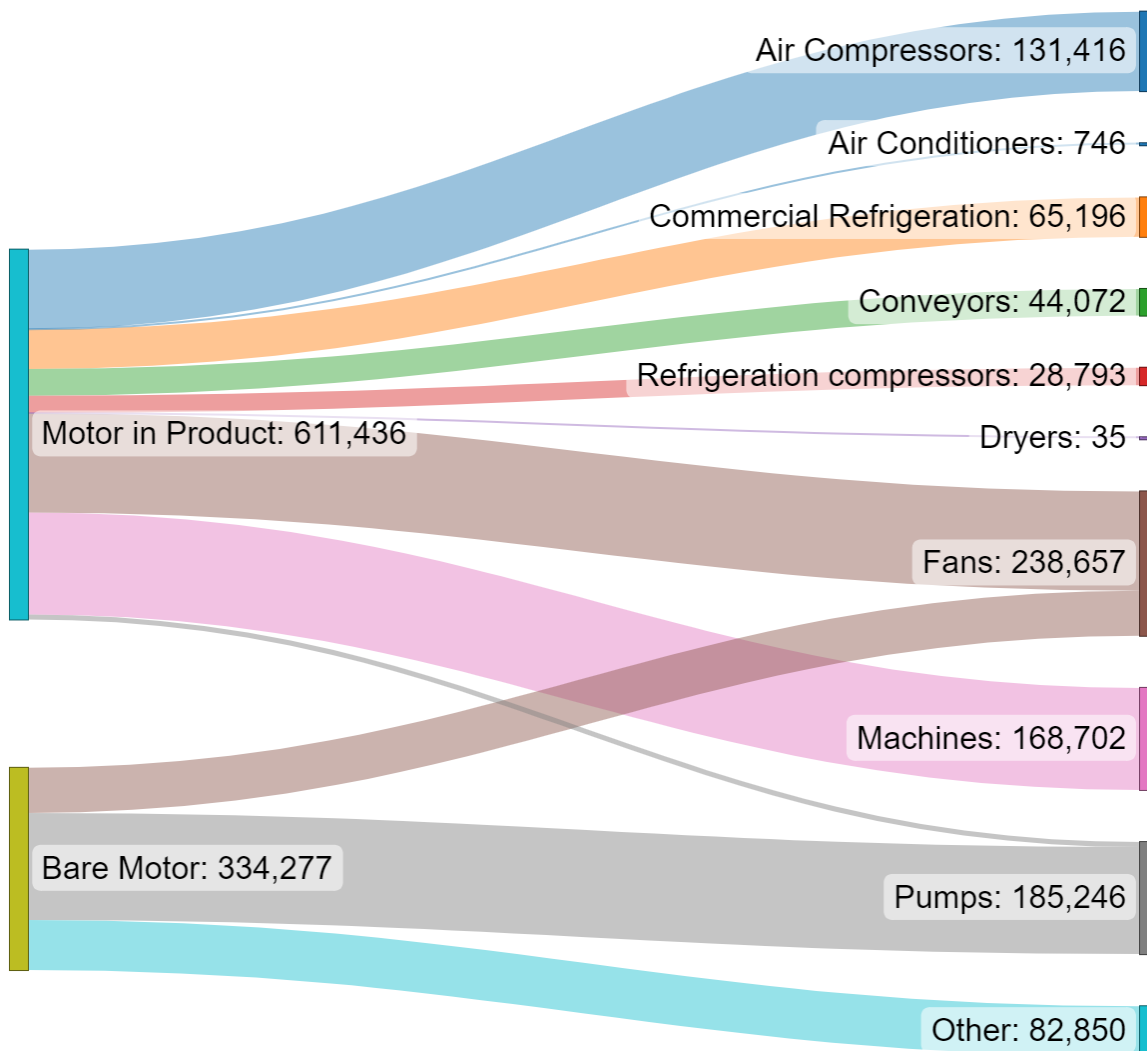

Notes: This shows imports for 2021, and is not net imports (i.e., excluding exports). The imports of bare motors are higher in 2021 than the 2019 net imports (approx. 200,000) used in the CBA model, as the 2021 bare motors imported included size categories below 0.12 kW and motors exported. The other category includes bare motors that are exported and those used in many of the applications, but cannot be disaggregated. EnergyConsult, 2023

Motor import data supplied for New Zealand contained apparent errors and inconsistencies and was not able to be analysed in a similar way to the Australian import data. However, data was extracted from EECA’s Energy End Use Database and analysed to show the following breakdown in energy consumption by sector and end use in Table 42 below. This is based on electricity used in all motors for New Zealand in 2022 and includes single phase as well as three phase electric motors. However, on the basis that approximately 80% of motors’ electricity consumption is used in three phase electric motors, it should be a useful guide to consumption by end use and sector.

Table 42: Electricity consumed by all motors in New Zealand: 2022

Sector	Sector Group	End Use	Elec cons GWh	Total for end use GWh	% of total
Dairy Product Manufacturing	Industrial	Compressed Air	70.6		
Food and Beverage Product Manufacturing (excluding Dairy, Meat, Seafood)	Industrial	Compressed Air	23.6		
Pulp, Paper and Converted Paper Product Manufacturing	Industrial	Compressed Air	3.3		
Wood Product Manufacturing	Industrial	Compressed Air	58.1		
Total for end use				156	6%
Dairy Product Manufacturing	Industrial	Fans	373.6		
Pulp, Paper and Converted Paper Product Manufacturing	Industrial	Fans	11.1		
Wood Product Manufacturing	Industrial	Fans	514.2		
Total for end use				899	32%
Dairy Cattle Farming	Agriculture, Forestry and Fishing	Pumping	367.8		
Non-Dairy Agriculture	Agriculture, Forestry and Fishing	Pumping	221.7		
Building Cleaning, Pest Control and Other Support Services	Commercial	Pumping	7.5		
Dairy Product Manufacturing	Industrial	Pumping	332.2		
Electricity, Gas, Water and Waste Services	Industrial	Pumping	602.5		
Food and Beverage Product Manufacturing (excluding Dairy, Meat, Seafood)	Industrial	Pumping	86.7		
Non-Metallic Mineral Product Manufacturing	Industrial	Pumping	2.2		
Pulp, Paper and Converted Paper Product Manufacturing	Industrial	Pumping	40.8		
Wood Product Manufacturing	Industrial	Pumping	96.9		
Total for end use				1758	63%
Grand Total				2812	

Source: EECA's Energy End Use Database – 2022 data

Appendix 4: Glossary

Term	Definition
\$M	Million dollars
AS/NZS	Australian / New Zealand standard
BAU	Business as usual
BCR	Benefit Cost Ratio
CO ₂ -e	Carbon dioxide equivalent
COP28	28th session of the Conference of the Parties (COP28) to the UN Framework Convention on Climate Change
CRIS	Consultation Regulation Impact Statement
Determination	Greenhouse and Energy Minimum Standards (Three Phase Cage Induction) Determination 2019 (Australia)
DCCEEW	Department of Climate Change, Energy, the Environment and Water (Australia)
E3 Program	Equipment Energy Efficiency Program (Australia and New Zealand)
EC	European Commission
ECMC	Energy and Climate Change Ministers Council
EEC Act	Energy Efficiency and Conservation Act (New Zealand)
EECA	Energy Efficiency and Conservation Authority (New Zealand)
ESCOG	Energy and Climate Change Senior Official Group
EU	European Union
GEMS	Greenhouse and Energy Minimum Standards (Australia)
GHG	greenhouse gas emissions
GWh	gigawatt hour – unit of electrical energy
IE2	International Efficiency Level 2 (high efficiency)
IE3	International Efficiency level 3 (premium efficiency)
IE4	International Efficiency level 4 (super premium efficiency)
IE5	International Efficiency level 5 (ultra premium efficiency)
IEA	International Energy Agency
IEC	International Electrotechnical Commission
ISO	International Organization for Standardization
kt	kilotonnes (thousand tonnes)
kWh	kilowatt hour – unit of electrical energy
MEPS	minimum energy performance standards
NPV	Net present value
OIA	Official Information Act 1982
OEM	Original equipment manufacturer
Regulations	Energy Efficiency (Energy Using Products) Regulation 2002 (New Zealand)
S1 – S9	Duty cycle designations to describe electrical motor operating conditions:
VAC	Volts alternating current
VSD	Variable frequency drive, also known as a variable speed drive

Appendix 5: References

AC electric motors, 2024, *Products three-phase*, November 2024, [UK motor information](#)

Australian Competition and Consumer Commission (ACCC), 2023, *Inquiry into the National Electricity Market report - December 2023*, Australian Competition and Consumer Commission, December 2023, [ACCC Inquiry into the National Electricity Market report - December 2023](#)

Australian Energy Market Commission (AEMC), 2024, *How the national energy objectives shape our decisions*, Australian Energy Market Commission, 28 March 2024, [AEMC how the national energy objectives shape our decisions](#)

Australian Energy Market Operator (AEMO), 2023, *Draft 2024 ISP forecast*, Australian Energy Market Operator, August 2023, [AEMO Draft 2024 ISP forecast](#)

Department of Climate Change, Energy, the Environment and Water (DCCEEW), 2012, *Greenhouse and Energy Minimum Standards Act 2012*, DCCEEW, November 2024, [Federal Register of Legislation - Greenhouse and Energy Minimum Standards Act 2012](#)

Department of Climate Change, Energy, the Environment and Water (DCCEEW), 2023, *Australia's emissions projections 2023*, Department of Climate Change, Energy, the Environment and Water, November 2023, [DCCEEW emissions projections](#)

Department of Climate Change, Energy, the Environment and Water (DCCEEW), 2019, *Greenhouse and Energy Minimum Standards (Three Phase Cage Induction Motors) Determination 2019*, DCCEEW, November 2024, [Three phase motors Determination](#)

Department of Energy (DoE), 2023, *Energy Conservation Program: Energy Conservation Standards for Electric Motors*, DoE, November 2024, [DoE three phase electric motor requirements](#)

Department of the Environment and Energy, 2019, *INDEPENDENT REVIEW OF THE GREENHOUSE AND ENERGY MINIMUM STANDARDS (GEMS) ACT 2012*, Department of the Environment and Energy, November 2024, [Final report](#)

E3 Product Profile, 2006, *Electric Motors 2013/Energetics Report 2006*

Electrical Engineering Portal, 2022, *Ten different duty types (load cycle) of a three-phase asynchronous motor*, Electrical Engineering Portal, [Duty types](#)

Energy Efficiency and Conservation Authority (EECA), 2000, *Energy Efficiency and Conservation Act 2000*, EECA, November 2024, [Energy Efficiency and Conservation Act 2000 No 14 \(as at 23 December 2023\), Public Act Contents – New Zealand Legislation](#)

Energy Efficiency and Conservation Authority, 2024, *Three-phase electric motors*, November 2024, [New Zealand motor requirements](#)

EnergyConsult, 2023, *Research and analysis of electric motor energy efficiency opportunities in Australia and New Zealand markets*, Department of Climate Change, Energy, the Environment and Water

European Commission, 2019, *COMMISSION REGULATION (EU) 2019/1781*, European Commission, November 2024, [EU commission three phase electric motor requirements](#)

EU, 2019, *Impact Assessment Commission Regulation (EU) .../... laying down ecodesign requirements for electric motors and variable speed drives pursuant to Directive 2009/125/EC of the European Parliament and of the Council and repealing Commission Regulation (EC) No 640/2009*

IEA 4E, 2015, *Energy Efficiency Roadmap for Electric Motors and Motor Systems*

New Zealand Climate Change Commission, 2021, *Ināia tonu nei: a low emissions future for Aotearoa*

International Energy Agency (IEA), 2011, *Energy Efficiency Policy Opportunities for Electric Motor-Driven*
IEA, November 2024, [IEA website energy efficiency policy opportunities for electric motor driven systems](#)

International Energy Agency (IEA), 2024, *Energy Efficiency 2022*, IEA, November 2024, [IEA website energy efficiency 2024](#)

Ministry for the Environment, 2023, *Greenhouse gas emissions targets and reporting*, Ministry for the Environment, November 2024, [MfE greenhouse gas emissions targets and reporting](#)

New Zealand Treasury, 2023, *Assessing climate change and environmental impacts in the CBAX tool*, The Treasury, New Zealand Government, December 2023, [The Treasury's CBAX Tool](#)

Office of Impact Analysis, 2024, *Regulatory Burden Measurement Framework*, Office of Impact Analysis, January 2025, [Regulatory Burden Measurement Framework](#)

Pitt & Sherry, 2009, *Development of an Electric Motor Stock Model for Australia Final Report*, prepared for Department of Environment Water Heritage and the Arts

The United Nations Climate Change Conference, 2023, *Global Renewables and Energy Efficiency Pledge*, United Nations, November 2024, [UN COP28 Pledge](#)

University of Coimbra, 2008, *EUP Lot 11 Motors Final Report*

Appendix 6: Electricity emissions factors

Table 43: GHG emission factors for electricity (kg CO₂-e/kWh) for Australia and New Zealand

Region/ year	2023	2024	2025	2026	2027	2028	2029	2030	2031	2032	2033	2034	2035	2036	2037	2038	2039	2040
NSW	0.730	0.630	0.560	0.420	0.320	0.300	0.300	0.200	0.110	0.060	0.020	0.030	0.030	0.029	0.029	0.028	0.027	0.027
ACT	0.730	0.630	0.560	0.420	0.320	0.300	0.300	0.200	0.110	0.060	0.020	0.030	0.030	0.029	0.029	0.028	0.027	0.027
NT	0.610	0.590	0.440	0.420	0.400	0.390	0.380	0.350	0.310	0.300	0.300	0.300	0.290	0.275	0.261	0.246	0.231	0.217
QLD	0.880	0.850	0.800	0.780	0.670	0.560	0.510	0.480	0.440	0.320	0.230	0.220	0.220	0.210	0.200	0.190	0.180	0.170
SA	0.320	0.220	0.180	0.170	0.080	0.100	0.100	0.080	0.110	0.120	0.140	0.190	0.210	0.198	0.186	0.174	0.162	0.150
TAS	0.130	0.050	0.020	0.040	0.040	0.030	0.030	0.020	0.010	0.010	0.010	0.010	0.020	0.020	0.020	0.020	0.020	0.020
VIC	0.850	0.810	0.750	0.740	0.690	0.640	0.430	0.420	0.410	0.340	0.260	0.130	0.010	0.015	0.021	0.026	0.031	0.037
WA	0.570	0.540	0.510	0.470	0.370	0.310	0.290	0.200	0.190	0.170	0.160	0.160	0.150	0.144	0.138	0.132	0.126	0.120
NZ	0.105	0.079	0.040	0.043	0.046	0.049	0.051	0.054	0.056	0.056	0.055	0.055	0.055	0.054	0.054	0.054	0.053	0.052

Sources: DCCEEW (2023) Table 46 Indirect scope 2 and 3 combined emissions factors in the baseline scenario and EECA (2024).